

 KTR Kupplungstechnik GmbH D-48407 Rheine	PIK - oil cooler Mounting Instructions	KTR-N 41028 E sheet: 1 edition: 5
---	---	---

The PIK is a connecting element between electro motor and hydraulik pump in combination with an oil - air cooler.

General Hints

Please read through these mounting instructions carefully before you assemble the PIK. Please pay special attention to the safety instructions!

The mounting instructions are part of your product. Please keep them carefully and close to the PIK. The copyright for these mounting instructions remains with **KTR Kupplungstechnik GmbH**.

Safety and Advice Hints



DANGER! Danger of injury to persons.



CAUTION! Damages on the machine possible.



ATTENTION! Pointing to important items.

General Hints to Danger



DANGER! With assembly and disassembly of the PIK's it has to be made sure that the entire drive train is protected against unintentional engagement. You can be seriously hurt by rotating parts. Please make absolutely sure to read through and observe the following safety instructions.

- All operations on and with the PIK have to be performed taking into account "safety first".
- Please make sure to disengage the power pack before you perform your work at the PIK.
- Protect the power pack against unintentional engagement, e. g. by providing hints at the place of engagement or removing the fuse for current supply.
- Do not touch the operation area of the machine as long as it is in operation.
- Please protect the rotating drive parts against unintentional touch. Please provide for the necessary protection devices and caps.

Proper Use

You may only assemble and disassemble the PIK if you

- have carefully read through the mounting instructions and understood them
- and if you are authorized and have proper skills

The PIK ring may only be used in accordance with the technical data (see hydraulic components catalogue). Unauthorized modifications on the PIK design are not admissible. We do not take any warranty for resulting damages. To further develop the product we reserve the right for technical modifications.

The **PIK** described in here corresponds to the technical status at the time of printing of these mounting instructions.

Schutzvermerk ISO 16016 beachten.	Gezeichnet: 16.10.06 Sha/Wy Geprüft: 16.10.06 Sha	Ersatz für: Ersetzt durch:
--------------------------------------	--	-------------------------------



The PIK is generally supplied ready for assembly.

Components of PIK

Component	Quantity	Designation
1	1	PIK (bellhousing with integrated cooler)
2	1	fan wheel
3 ¹⁾	1 ²⁾	PIK feet
4 ¹⁾	2	damping rod

1) Delivery only on customer's request.

2) Quantity = 1 set (1 set consists of 4 feet incl. cap screws)

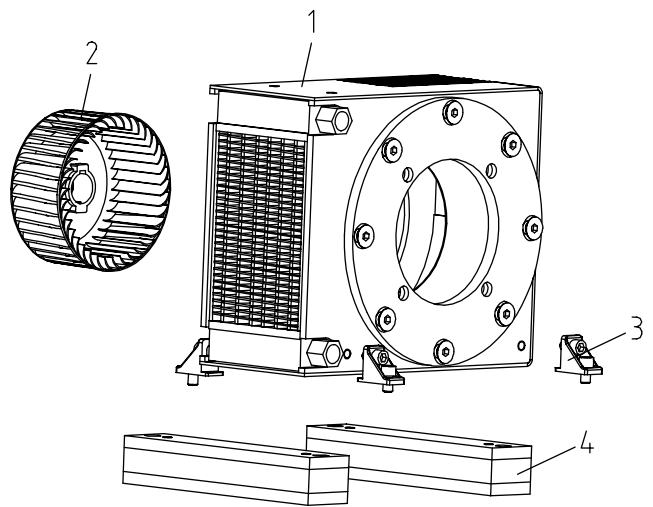

picture 1: PIK

Hints concerning the PIK

- The max. permissible operating pressure for the installed heat exchanger is 15 bar.



CAUTION!

Peak pressures must be avoided.

The permanent operating pressure should not exceed 10 bar during static operation and be max. 6 bar in case of pulsating dynamical load. In case of dynamical load peak pressures of more than 10 bar must be avoided.



ATTENTION!

The sense of rotation of the engine is right - from the pump shaft!

- Please see diagrams 1 to 8 regarding the permissible oil quantity flowing through and the pressure difference. If the max. permissible quantities flow through, please make sure that there is a free flowing-through of the cooler output line in order to avoid peak pressures.



ATTENTION!

Please consult with our Engineering Department in case of quantities flowing through which are higher than indicated in these diagrams.

- The position to assemble the PIK oil cooler is optional.



CAUTION!

Please make sure that there is free space approx. 10 cm in front of and behind of the air input and air output. The performance of the PIK is increased by the natural flow direction of warm air if the air output is on the top.

The fixing threads of the PIK feet are respectively arranged.

Schutzvermerk ISO 16016 beachten.	Gezeichnet: 16.10.06 Sha/Wy	Ersatz für:
	Geprüft: 16.10.06 Sha	Ersetzt durch:



Design of the PIK system

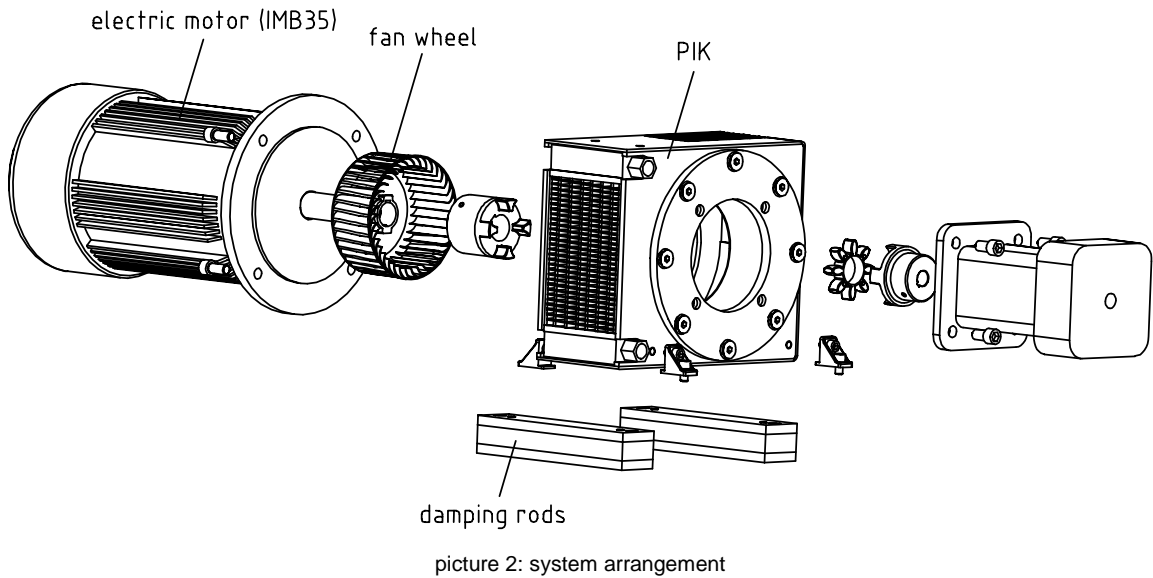

Assembly / Starting the PIK

- The PIK (bellhousing with integrated cooler) is put onto the engine centering / pump centering and screwed.
- The screw length must be selected in a way that at least the total length of the thread in the bellhousing is used.
The tightening torques T_A are indicated in the following table 1 for assembly PIK with electro motor and table 2 for assembly PIK with pump.

Table 1:

cap screw DIN EN ISO 4762 ¹⁾	M8	M10	M12	M16	M20
tightening torque ²⁾	25 Nm	49 Nm	86 Nm	210 Nm	410 Nm

Table 2:

cap screw DIN EN ISO 4762 ¹⁾	M5	M6	M8	M10	M12	M16	M20
tightening torque	3 Nm	5 Nm	13 Nm	25 Nm	40 Nm	100 Nm	190 Nm

1) min. property class 8.8

2) tightening torques of the property class 8.8



ATTENTION!

The screws must be generally used with Loctite, Omnifit 230M or comparable adhesives for securing.

- The connection for cooler input or output is optional.



CAUTION!

When the oil connection ducts are assembled or disassembled you have to hold up hexagonally.

The max. tightening torque is 40 Nm.

Schutzvermerk ISO 16016 beachten.	Gezeichnet:	16.10.06 Sha/Wy	Ersatz für:
	Geprüft:	16.10.06 Sha	Ersetzt durch:



Assembly / Starting the PIK

Continuation:

- You generally need fixing threads to fix the PIK feet.
The nylon stoppers in the threads must be removed before the assembly.
Hexagon socket screws acc. to DIN EN ISO 4762 must be used.
The tightening torque T_A of the screws to the PIK is indicated in table 1.
- Fixing threads are generally planned to fix the tank (type V1).
The nylon stoppers in the threads must be removed before the assembly.
The screw tightening torques of the screws from the tank cover to the PIK are indicated in table 1.



CAUTION!

The oil connection pieces must show to the direction of the engine (The heat exchanger can be turned if V1 is used)!

- The fan wheel must be pushed onto the engine shaft until the stop and secured against axial displacement.

Safety device against axial displacement:

Fan wheel with radial safety device: The screw tightening torques for the assembly of the fan wheel are shown in table 2 (see picture 3).

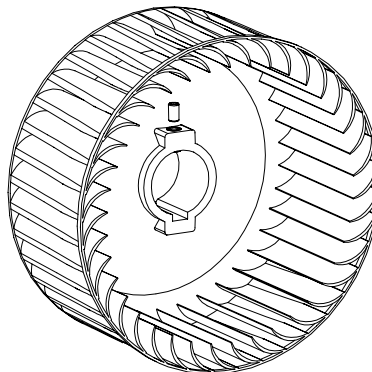

picture 3: fan wheel with radial safety device

- The mounting instructions for the respective coupling type are generally valid for the assembly of the coupling. The dimensions for the assembly of the coupling hubs are shown on the drawing of the respective engine-pump combination.
- The DT damping ring can only be used in the variation DT.../2.
Before the assembly the nylon caps in the threads must be removed.
Hexagon socket screws acc. to DIN EN ISO 4762 must be used.
The DT damping ring must be screwed with the PIK. Please make sure that the hexagon socket screws are plugged into the DT damping ring through the cylinder bores and screwed into the PIK housing.
The tightening torques of the screws from the DT damping ring to the PIK housing are mentioned in table 1.

Schutzvermerk ISO 16016 beachten.	Gezeichnet: 16.10.06 Sha/Wy	Ersatz für:
	Geprüft: 16.10.06 Sha	Ersetzt durch:



Assembly / Starting the PIK

Continuation:

- Position of the PIK oil cooler in the hydraulics circle
The PIK oil cooler must be the last element in the oil circulation in order to avoid pressure. Filter units (also designs with „by-pass“ valve) must be positioned in front of the PIK oil cooler since sudden changes of the volume flow lead to short-term peak torques which are not compensated by sludge valves.
- Operating temperature



CAUTION!

Before the initial operation please make sure that the max. oil temperature of +80 °C is not exceeded.

Maintenance Hints

The PIK oil coolers are maintenance-free in many points. Due to the vacuum principle and the respective airflow dirt can be easily recognized from the outside and can be cleaned from the outside without having to disassemble the heat exchanger (e. g. with a vacuum cleaner). By reason of the even surface of the types the housing can be easily cleaned from the outside.

Technical Data

Performance of the fan with 1500 1/min.

PIK 200 = 25 W	PIK 300 = 125 W
PIK 250 = 40 W	PIK 350 = 230 W

Cooling effect P_K [KW] depending on volume flow and temperature difference between oil intake and air intake.

Speed of fan 1500 1/min.

PIK 200

cooling effect P_K [KW]



diagramme 1

Pressure difference p [bar] depending on volume flow and viscosity of hydraulic fluid.

PIK 200

pressure difference p [bar]

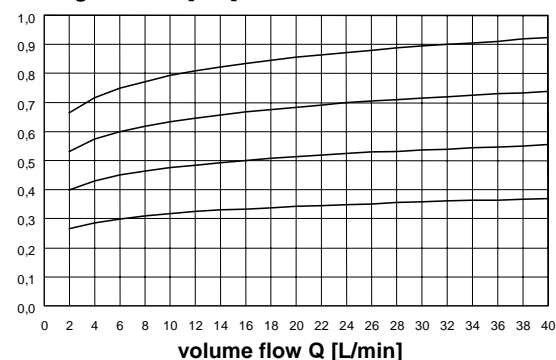

diagramme 2

Schutzvermerk ISO 16016 beachten.	Gezeichnet: 16.10.06 Sha/Wy	Ersatz für:
	Geprüft: 16.10.06 Sha	Ersetzt durch:

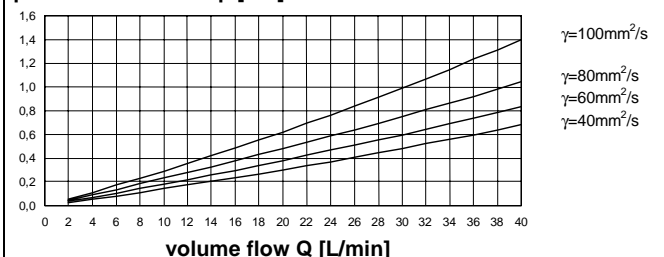

Technical Data

Continuation:

Cooling effect P_K [KW] depending on volume flow and temperature difference between oil intake and air intake.

Speed of fan 1500 1/min.

Pressure difference p [bar] depending on volume flow and viscosity of hydraulic fluid.

PIK 250

cooling effect P_K [KW]



diagramme 3

PIK 250

pressure difference p [bar]

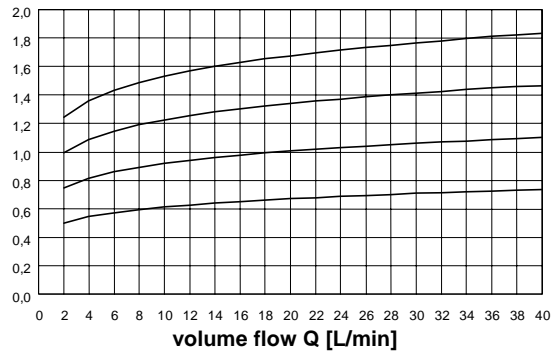

diagramme 4

PIK 300

cooling effect P_K [KW]

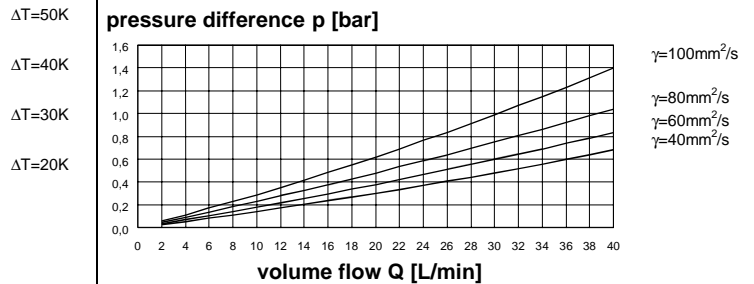

diagramme 5

PIK 300

pressure difference p [bar]

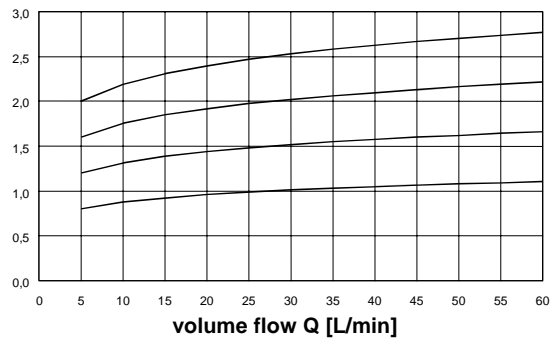

diagramme 6

PIK 350

cooling effect P_K [KW]

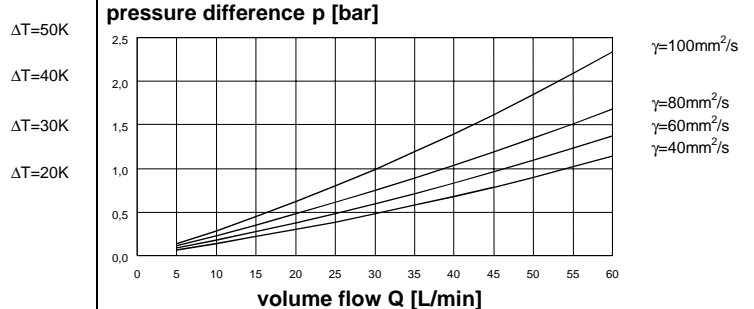

diagramme 7

PIK 350

pressure difference p [bar]

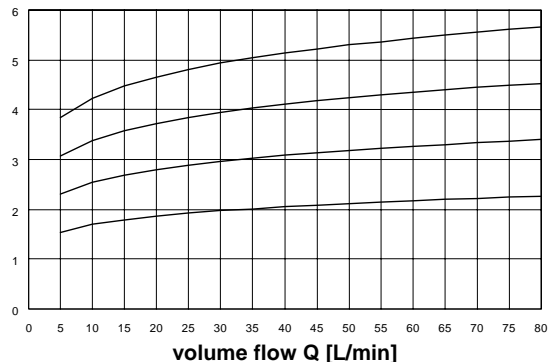
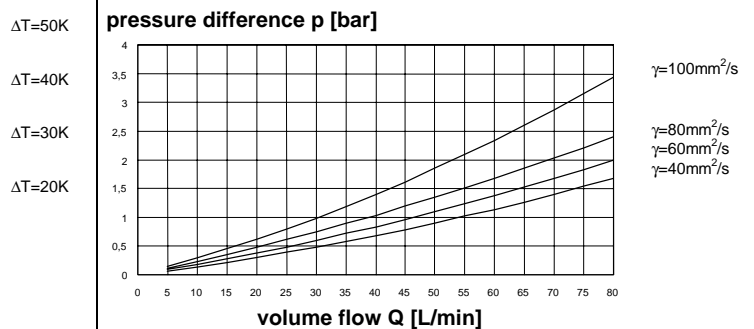

diagramme 8

Schutzvermerk ISO 16016 beachten.	Gezeichnet: 16.10.06 Sha/Wy	Ersatz für:
	Geprüft: 16.10.06 Sha	Ersetzt durch: