

CLAMPEX®

Shaft-hub-connection

KTR Precision Joints

according to DIN 808

Made for Motion



Table of contents



CLAMPEX®	
Shaft-hub-connection	277
Factors, hints	279
External clamping sets	
KTR 620	280
KTR 603	283
Internal clamping sets, self-centering	
KTR 105, compact design	286
KTR 200/KTR 201, without/with axial ring	288
KTR 203/KTR 206, short design, without/with axial ring	290
KTR 250, for thin-walled hubs	292
KTR 225, one outside diameter for different shaft diameters	294
KTR 400, for high torques	296
KTR 130, assembly by using central clamping nut and KTR 131, assembly by using hexagon locking nuts	298
Internal clamping sets, not self-centering	
KTR 100, axial fixing of the hubs	300
KTR 150, pressure flange and distance ring necessary in addition	302
Calculation	304
Calculation of hubs	305
KTR 200 with torsionally flexible ROTEX® coupling	306
Series on request	307
KTR clamping nuts	
Large screw connections to be assembled easily and quickly	308
KTR Precision joints	
Type G and GD according to DIN 808 with plain bearing	309
Type H and HD according to DIN 808 with needle bearing	310
Type GA and HA acc. to DIN 808 with needle bearing (extendable)	311
Type X and XD acc. to DIN 808 with plain bearing (stainless steel 1.4301)	312
Type GR and HR with quick locking	313
Selection and determination of size acc. to DIN 808 with plain/needle bearing	314

Factors, hints

Reduction of costs!
Reduction of components!
Reduction of dimensions!

Factors like cost reduction, material saving, simplified production processes, shorter delivery times of material are already determined by designing and development. Anyway, the growing demands can no longer be satisfied by keyway connections.

In this case the use of **CLAMPEX® clamping elements** offers new possibilities as a shaft-hub-connection

- Material saving by smaller shaft and hub dimensions
- Simplified production processes
- Suitable for modern drive systems
- Easy assembly and disassembly with standard tools
- Ideal for drives with high vibratory loads, e. g. acceleration and braking
- Produce connections that are permanently free from destruction, i. e. no shearing off of keyways, dowel pins, pins, etc.
- Specifically suitable for high-speed drives
- Insensitive to dirt
- Reusable repeatedly
- Overload protection of the machine components by slipping (repeated slipping should be avoided)
- Low stress concentration on the shaft (stress concentration factor on request)
- Corrosion- and acid-resistant surface coating for food-processing industry, marine industry and chemical industry on request
- Simple calculation of the clamping connection

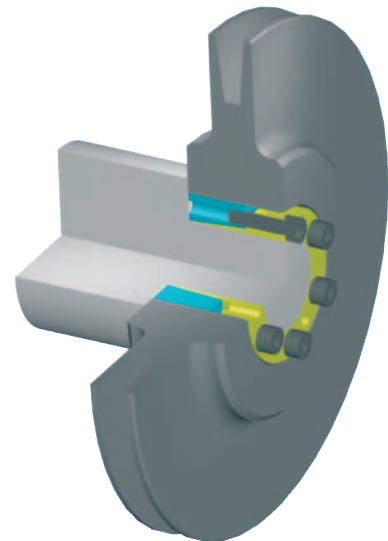
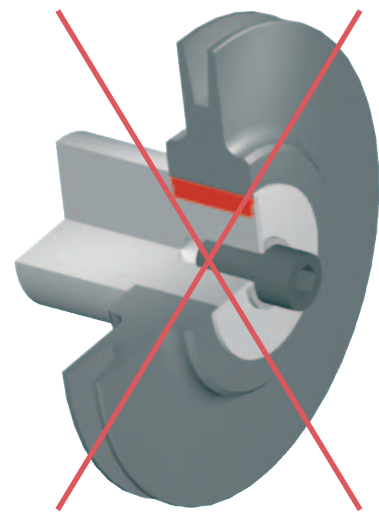

Advice for selection

The transmission data mentioned in the catalogue are parameters found out by calculations. Subject to tests and the physical coefficient of friction slight deviations from the transmission values may arise. Copyright according to ISO 16016. We reserve the right for modifications of dimensions and designs.

KTR 620

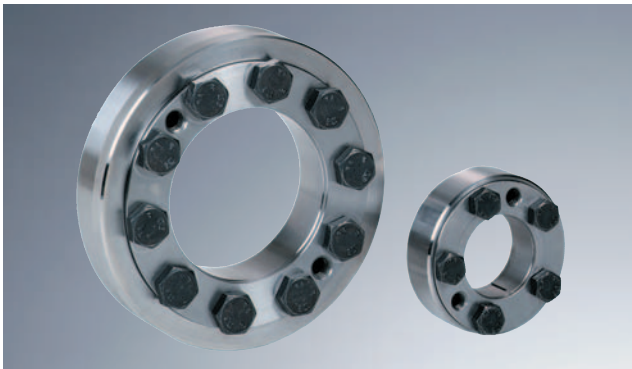

- Applications on hollow shafts, slip-on gears, couplings, mechanical shrink connections
- Suitable for high torque loads
- Easy assembly by visual mounting groove
- Corrosion-resistant outer ring (phosphated)
- Good centering and concentricity characteristics
- KTR 620 FK flange coupling
(Please order dimension sheet M494133.)
- KTR 625 for higher torques
(Please order dimension sheet M462972.)
- Mounting instructions at www.ktr.com

Outer ring
phosphated and
conus contact
surfaces greased

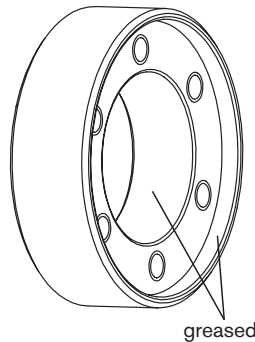

Inner ring

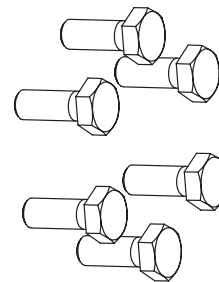
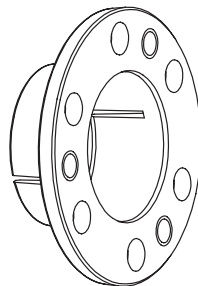

Assembly

Clean and degrease the contact surfaces of shaft and hub (internal hollow shaft). Slightly unscrew the clamping screws and put the clamping set externally onto the hub/hollow shaft. Before tightening the clamping screws please assemble the shaft. Evenly tighten the diametrically opposite clamping screws until the front surfaces of the outer and inner rings are flush. The max. screw tightening torque indicated must not be exceeded. The values for T and F_{ax} indicated in the table relate to an assembly with greased external clamping set. The external clamping sets are delivered in greased condition. When assembling grease-free external clamping sets the values shown in the table and the values calculated are different. In case of questions, please feel free to contact us.

Note: Contact surfaces of shaft and hub bore (internal hollow shaft) must not be greased or oiled.

Disassembly

All clamping screws must be unscrewed evenly and one after another. Do not completely unscrew the clamping screws off the thread. Loosen the external taper ring in the inner ring with the forcing thread.

Tolerances, surfaces

One accurate turning process is sufficient:

$$RZ \leq 16\mu\text{m}$$

Maximum permissible tolerances:

d = f7 for the hub (external hollow shaft)

$$d_w = h6/H7$$

$$d_w > \varnothing 160 - g6/H7$$

Axial displacement

During the tightening of the screws there is no axial displacement of the hub towards the shaft.

Ordering example:	KTR 620	20	x	47
	Type	Size of inside diameter d		Size of outside diameter D

KTR 620 – Technical data



Frictionally engaged connection of a DATAFLEX® torque measuring shaft with KTR 620

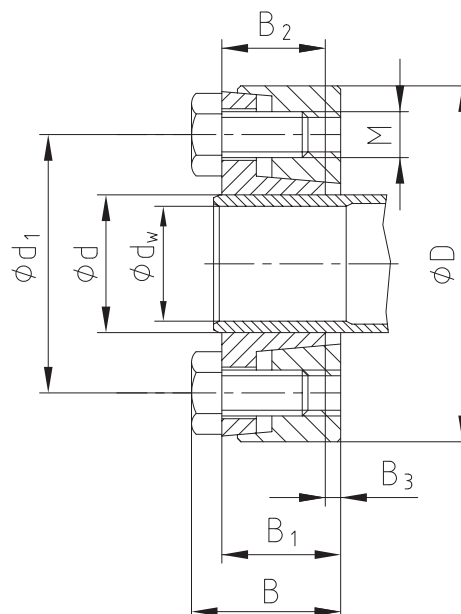

CLAMPEX® – KTR 620															
d x D [mm]	Shaft diameter d_w [mm]	Transmittable torque or axial force		Dimensions [mm]					Clamping screws DIN EN ISO 4017 - 10.9 $\mu_{ges.}=0,10$			Forcing thread		Surface pressure clamping set/hollow shaft	Weight [-kg]
		T [Nm]	F_{ax} [kN]	B	B ₁	B ₂	B ₃	d ₁	M	z number	T _A [Nm]	M ₁	z ₁	P _H [N/mm ²]	
16 x 41	13	85	13	19,0	15	13,5	1,5	28	M6	3	12	M6	2	281	0,15
	14	105	15												
20 x 47	17	155	18	19,0	15	13,5	1,5	32	M6	4	12	M6	2	288	0,17
	18	175	19												
24 x 50	19	235	24	22,0	18	16	2	36	M6	5	12	M6	2	266	0,25
	22	305	28												
30 x 60	24	390	33	24,0	20	18,8	2	44	M6	6	12	M6	2	256	0,30
	25	430	34												
36 x 72	26	480	37	27,5	22	20	2	52	M8	5	30	M8	2	256	0,49
	28	510	38												
38 x 72	30	690	46	29,5	24	22	2	54	M8	6	30	M8	2	253	0,61
	33	820	50												
40 x 80	34	910	54	31,5	26	23,5	2,5	61	M8	8	30	M8	2	254	0,84
	35	850	49												
44 x 80	37	980	53	34,5	29	26	3	68	M8	6	30	M8	2	231	1,20
	38	1180	62												
50 x 90	40	1320	66	34,5	29	26	3	72	M8	8	30	M8	2	249	0,84
	42	1470	70												
55 x 100	42	1400	67	34,5	29	26	3	80	M8	8	30	M8	2	223	1,20
	45	1650	73												
60 x 110	48	1900	79	34,5	29	26	3	86	M8	9	30	M8	3	223	1,50
	50	2050	82												
62 x 110	52	2200	85	34,5	29,5	26	3,5	86	M8	9	30	M8	3	216	1,60
	50	1900	76												
68 x 115	55	2450	89	38,0	31	27	4	100	M10	10	59	M10	2	222	1,60
	60	3000	100												
75 x 138	55	2650	96	38,0	31	27	4	104	M10	10	59	M10	2	227	2,60
	60	3250	108												
80 x 141	65	3850	118	38,0	31	27	4	104	M10	10	59	M10	2	224	2,80
	60	3350	112												
80 x 141	65	3980	122	38,0	31	27	4	104	M10	10	59	M10	2	224	2,80
	70	4620	132												

Other sizes on request.
Inner ring slotted up to size 40 x 80, all sizes of outer ring phosphated.

KTR 620 – Technical data

CLAMPEX® – KTR 620															
d x D [mm]	Shaft diameter d _w [mm]	Transmittable torque or axial force		Dimensions [mm]					Clamping screws DIN EN ISO 4017 - 10.9 uges.=0,10			Forcing thread		Surface pressure clamping set/hollow shaft	Weight [~kg]
		T [Nm]	F _{ax} [kN]	B	B ₁	B ₂	B ₃	d ₁	M	z number	T _A [Nm]	M ₁	z ₁	P _H [N/mm ²]	
90 x 155	65	5200	160												
	70	6000	171	45	38	34	4	114	M10	11	59	M10	2	219	3,40
	75	6900	184												
100 x 170	70	6600	189												
	75	7600	203	50	43,5	39	4,5	124	M10	14	59	M10	2	206	4,60
	80	8600	215												
110 x 185	80	10600	265												
	85	11900	280	57	49	43,5	5	136	M12	12	100	M12	2	212	6,20
	90	13300	296												
120 x 197	85	12700	299												
	90	14200	316	61	53	48	5	147	M12	14	100	M12	2	205	7,40
	95	15700	331												
125 x 215	90	14600	324												
	95	16000	337	61	53,5	48	5,5	158	M12	14	100	M12	2	215	9,30
	100	17500	350												
130 x 230	95	18600	392												
	100	20300	406	66,9	57,5	51	6,5	165	M14	12	160	M14	3	225	11,90
	110	23600	429												
140 x 230	100	20100	402												
	105	21700	413	67	58	51	6	172	M14	12	160	M14	3	205	11,00
	115	25150	437												
155 x 263	110	27400	498												
	115	29600	515	72	63	55	7,5	186	M14	14	160	M14	3	212	16,00
	125	32000	533												
165 x 290	120	41500	692												
	125	44300	709	78	68	61	7,5	198	M16	12	250	M16	2	223	22,30
	135	47200	726												
175 x 300	130	47600	732												
	135	50500	748	78	69	61	8	208	M16	14	250	M16	4	216	23,30
	140	53500	764												
185 x 320	140	66000	943												
	145	69900	964	95,5	85,5	77,5	8	222	M16	16	250	M16	4	201	33,40
	150	73500	980												
200 x 340	150	82000	1093												
	160	91000	1138	98	88	77,5	8	238	M16	16	250	M16	4	280	37
	165	102000	1236												
220 x 370	160	105000	1313												
	170	122000	1435	120	107,5	96,5	8,5	268	M20	15	480	M20	3	250	53
	180	138000	1533												
240 x 405	170	125000	1471												
	180	145000	1611	123,5	111	98	11	288	M20	16	480	M20	4	276	66
	200	182000	1820												
260 x 430	190	165000	1737												
	200	190000	1900	138	125,5	110,5	9,5	312	M20	16	480	M20	4	278	80
	220	238000	2164												
280 x 460	210	220000	2095												
	220	245000	2227	152,5	140	121	14	334	M20	18	480	M20	6	265	103
	240	300000	2500												
300 x 485	220	297000	2700												
	230	330000	2870	155	140	124	16	360	M24	16	840	M24	4	276	116
	250	399000	3192												
320 x 520	240	331000	2758												
	250	365000	2920	157	142	124	18	380	M24	18	840	M24	6	290	134
	270	437000	3237												
340 x 570	250	429000	3432												
	260	469000	3608	174	159	139	20	402	M24	18	840	M24	6	288	185
	280	556000	3971												
360 x 590	270	545000	4037												
	280	592000	4229	178	163	143	20	424	M24	20	840	M24	5	292	207
	290	694000	4786												

Other sizes on request.
Inner ring slotted up to size 40 x 80, all sizes of outer ring phosphated.

KTR 603



- „Typical external clamping set“
- For average and high torque loads
- Typical applications: hollow shafts, slip-on gears
- For internal diameters $d=320$ to 500 mm please order dimension sheet M482352.
- KTR 603 GT external clamping set separated (Please order dimension sheet M483039.)
- KTR 603 FK flange coupling (Please order dimension sheet M494196.)
- Mounting instructions at www.ktr.com

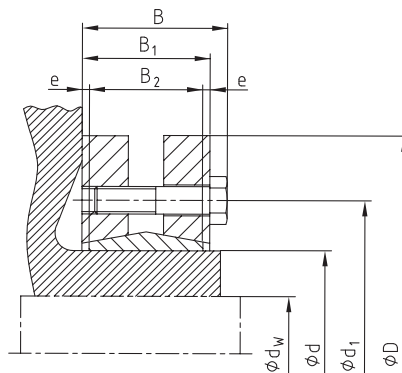

Assembly

Clean and degrease the contact surfaces of shaft and hub (hollow shaft inside). Assemble the external clamping set onto the hub (hollow shaft outside). In the area of the external clamping set the external surface of the hub (hollow shaft outside) may be lubricated. Before tightening the clamping screws, assemble the shaft or push on the hub (hollow shaft). Tighten the clamping screws by degrees and evenly one after the other until the screw tightening torque T_A mentioned in the table is achieved. Several tightening processes are necessary to achieve the requested T_A figure. The figures T and F_{ax} mentioned in the table were calculated for an assembly with oiled/greased external clamping set. The external clamping sets are delivered with oil/grease. For the assembly of external clamping sets without oil/grease the figures mentioned in the table will deviate. Please contact us for any questions you may have.

Note: Do not use any oil with molybdenum disulphide between the contact surfaces of shaft and hub bore (hollow shaft inside).

Disassembly

All clamping screws must be unscrewed evenly and successively. Do not completely unscrew the clamping screws off the thread. Usually the clamping elements release automatically.

Tolerances, surfaces

One accurate turning process is sufficient:
 $RZ \leq 16\mu\text{m}$

Maximum permissible tolerances:
 $d = h8$ for the shaft

Tolerances for d_w

For d_w from 18 to 30 mm **H6 / j6**
For d_w from 31 to 50 mm **H6 / h6**

For d_w from 51 to 80 mm **H6 / g6**
For d_w from 81 to 500 mm **H7 / g6**

* In general bigger tolerances are possible. Please contact us!

Axial displacement

During the tightening of the screws there is no axial displacement of the hub towards the shaft.

Ordering example:	KTR 603	44	x	80
	Type	Size of inside diameter d		Size of outside diameter D

KTR 603 – Technical data

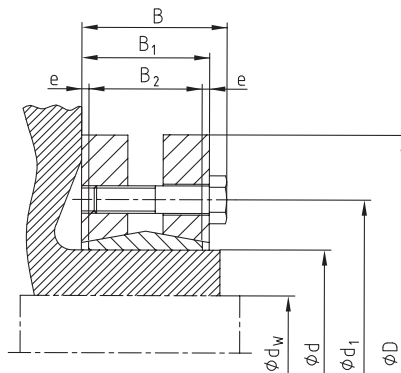

CLAMPEX® – KTR 603														
d x D [mm]	Shaft diameter d _w [mm]	Transmittable torque or axial force		Dimensions [mm]					Clamping screws DIN EN ISO 4014 - 10.9 $\mu_{ges.}=0,10$			Surface pressure clamping set/hollow shaft	Weight [-kg]	Stock programme
		T [Nm]	F _{ax} [kN]	B	B ₁	B ₂	e	d ₁	M	z number	T _A [Nm]	P _H [N/mm ²]		
14 x 38	10	28	5	14,5	11	9	1,0	24	M5 ¹⁾	4	3,5	388	0,15	●
	11	38	7											
	12	50	9											
16 x 41	12	50	9	18,5	15	11	2,0	26	M5 ¹⁾	5	4	310	0,20	
	13	70	10											
	14	90	13											
24 x 50	19	180	26	22,5	19	14	2,5	36	M5 ¹⁾	6	5	286	0,20	●
	20	210	27											
	21	250	29											
30 x 60	24	310	25	24,5	21	16	2,5	44	M5 ¹⁾	6	6	233	0,30	●
	25	340	27											
	26	380	29											
36 x 72	28	460	33	27	23	18	2,5	52	M6	5	12	307	0,45	●
	30	590	39											
	31	630	40											
44 x 80	32	630	40	29	25	20	2,5	61	M6	7	12	317	0,60	●
	35	780	44											
	36	860	48											
50 x 90	38	940	49	31	27	22	2,5	70	M6	8	12	289	0,80	●
	40	1100	55											
	42	1300	62											
55 x 100	42	1200	57	34	30	23	3,5	75	M6	8	12	252	1,10	●
	45	1500	66											
	48	1900	79											
62 x 110	48	1800	75	34	30	23	3,5	86	M6	10	12	279	1,30	●
	50	2200	88											
	52	2400	92											
68 x 115	50	2000	80	34	30	23	3,5	86	M6	10	12	255	1,40	●
	55	2500	91											
	60	3100	103											
75 x 138	55	2500	92	37,5	32	25	3,5	100	M8	7	30	273	1,70	●
	60	3200	107											
	65	3900	121											
80 x 145	60	3200	107	37,5	32	25	3,5	100	M8	7	30	256	2,20	●
	65	3900	120											
	70	4600	131											
85 x 155	65	4800	148	43,5	38	30	4,0	114	M8	10	30	285	3,40	
	70	6100	175											
	75	7400	201											
90 x 155	65	4700	145	44,5	39	30	4,5	114	M8	10	30	271	3,30	●
	70	6000	172											
	75	7200	194											

● Clamping sets available from stock.

¹⁾ The clamping screws are designed as per DIN EN ISO 4014 – 8.8 mit $\mu_{ges.}=0,12$
Other sizes on request.

KTR 603 – Technical data

CLAMPEX® – KTR 603														
d x D [mm]	Shaft diameter dw [mm]	Transmittable torque or axial force		Dimensions [mm]					Clamping screws DIN EN ISO 4014 - 10.9 $\mu_{ges.}=0,10$		Surface pressure clamping set/ hollow shaft	Weight [-kg]	Stock programme	
		T [Nm]	F _{ax} [kN]	B	B ₁	B ₂	e	d ₁	M	z number	T _A [Nm]			P _H [N/mm ²]
100 x 170	70	6900	199											
	75	7500	199	49,5	44	34	5,0	124	M8	12	30	258	4,60	●
	80	9000	225											
110 x 185	75	7200	194											
	80	9000	227	56,5	50	39	5,5	136	M10	9	59	244	5,90	●
	85	11000	259											
115 x 188	80	8500	213											
	85	10000	237	56,5	50	39	5,5	141	M10	9	59	234	6,30	
	90	12000	267											
120 x 215	80	10500	280											
	85	13200	300	58,5	52	42	5,0	160	M10	12	59	277	8,00	
	90	14400	330											
125 x 215	85	11000	261											
	90	13000	290	58,5	52	42	5,0	160	M10	12	59	266	8,60	●
	95	15000	318											
130 x 215	90	13700	306											
	95	15800	334	58,5	52	42	5,0	160	M10	12	59	285	8,20	
	100	18200	365											
140 x 230	95	15000	350											
	100	17000	342	67,5	60	46	7,0	175	M12	10	100	264	10,00	●
	105	20000	382											
155 x 265	105	20000	381											
	110	23000	415	71,5	64	50	7,0	192	M12	12	100	263	15,00	●
	115	26000	453											
165 x 290	115	36000	626											
	120	39000	648	81	71	56	7,5	210	M16	8	250	277	22,00	●
	125	44000	702											
175 x 300	125	40000	642											
	130	44000	677	81	71	56	7,5	220	M16	8	250	261	23,00	●
	135	49000	726											
185 x 330	135	55000	816											
	140	60000	855	96	86	71	7,5	236	M16	10	250	244	36,00	
	145	65000	902											
195 x 350	140	66000	943											
	150	76000	1013	96	86	71	7,5	246	M16	12	250	277	40,00	
	155	82000	1057											
200 x 350	150	73700	980											
	155	79800	1000	96	86	71	7,5	246	M16	12	250	270	48,00	
	160	85800	1070											
220 x 370	160	95000	1194											
	165	102000	1244	114	104	88	8,0	270	M16	15	250	248	54,00	
	170	110000	1293											
240 x 405	170	120000	1408											
	180	140000	1558	121,5	109	92	8,5	295	M20	12	490	272	67,00	
	190	160000	1690											
260 x 430	190	165000	1476											
	200	185000	1851	132,5	120	103	8,0	321	M20	14	490	262	82,00	
	210	204000	2008											
280 x 460	210	216000	2067											
	220	245000	2222	146,5	134	114	10,0	346	M20	16	490	251	102,0	
	230	270000	2352											
300 x 485	230	274000	2430											
	240	296000	2560	154,5	142	122	10,0	364	M20	18	490	246	118,0	
	245	316000	2630											
320 x 520	240	311000	2640											
	250	340000	2780	155	142	122	10	386	M20	20	490	257	131	
	260	375000	2900											
340 x 570	250	389000	3115											
	260	422000	3245	169	156	134	11	408	M20	24	490	263	186	
	270	459000	3400											
360 x 590	280	462000	3300											
	290	500000	3460	175	162	140	11	432	M20	24	490	238	204	
	300	530000	3600											

● Clamping sets available from stock.

¹⁾ The clamping screws are designed as per DIN EN ISO 4014 – 8.8 mit $\mu_{ges.}=0,12$
Other sizes on request.

KTR 105 (self-centering)

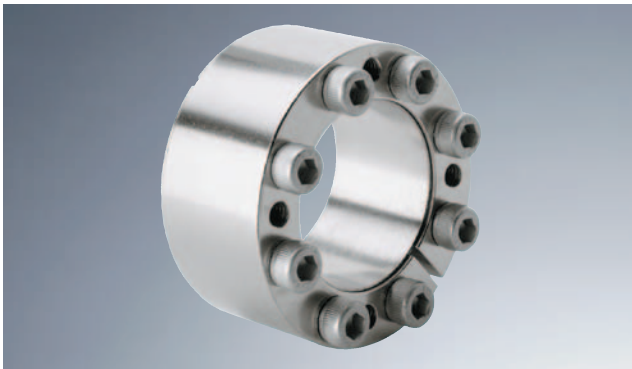

- Compact design
- Short assembly and disassembly times
- Suitable for small servo motors/pulleys
- QPQ surface protection on request
- Mounting instructions at www.ktr.com

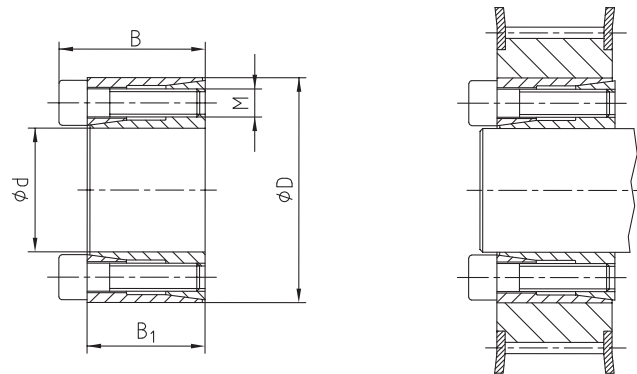

Assembly

Clean the contact surfaces of the clamping set as well as the shaft and the hub and afterwards apply thin-bodied oil. Insert the clamping set into hub fit and push it onto the shaft. Tighten the clamping screws crosswise, evenly and by degrees to the tightening torque T_A mentioned by means of the torque wrench. Check the tightening torque of all clamping screws in the order of arrangement. The figures T and F_{ax} mentioned in the table were calculated for an assembly with oil.

Note: Oils and greases containing molybdenum disulphide or high-pressure additions, additions of teflon and silicone as well as sliding grease paste reducing the coefficient of friction considerably must not be used. For assembly of clamping set tapers without oil, the figures mentioned in the table and calculated figures deviate.

Disassembly

Unscrew the clamping screws. Screw the screws into the forcing threads, tighten them crosswise by degrees and evenly until the rear taper ring is released. For repeated application oil the screws and threads.

Tolerances, surfaces

One accurate turning process is sufficient:
 $RZ \leq 16\mu m$

Maximum permissible tolerances:
h9 for the shaft - H9 for the hub

Axial displacement

During the assembly a slight axial displacement of the hub towards the shaft may arise.

Centering

The clamping element KTR 105 is **self-centering**. Between shaft and hub the concentricity of the clamping elements is between **0,02 mm** and **0,04 mm**.

Ordering example:	KTR 105	8	x	18
	Type	Size of inside diameter d		Size of outside diameter D

KTR 105 (self-centering) – Technical data

CLAMPEX® – KTR 105											
d x D [mm]	Dimensions [mm]		Clamping screws DIN EN ISO 4762 - 12.9 $\mu_{ges.} = 0,14$			Transmittable torque or axial force		Surface pressure between clamping set		Weight [-kg]	Stock programme
	B	B1	M	z number	T _A [Nm] ¹⁾	T [Nm]	F _{ax} [kN]	Shaft P _W [N/mm ²]	Hub P _N [N/mm ²]		
5 x 16	13,5	11	M2,5	3	1,2	6	3	196	61	0,010	
6 x 16	13,5	11	M2,5	3	1,2	8	3	163	61	0,012	●
6,35 x 16	13,5	11	M2,5	3	1,2	8	3	154	61	0,012	
7 x 17	13,5	11	M2,5	3	1,2	9	3	140	58	0,013	
8 x 18	13,5	11	M2,5	3	1,2	10	3	123	54	0,015	●
9 x 20	15,5	13	M2,5	4	1,2	16	3	121	54	0,020	●
9,53 x 20	15,5	13	M2,5	4	1,2	16	3	115	54	0,020	
10 x 20	15,5	13	M2,5	4	1,2	17	3	109	54	0,019	●
11 x 22	15,5	13	M2,5	4	1,2	19	3	99	50	0,024	●
12 x 22	15,5	13	M2,5	4	1,2	21	3	91	50	0,022	●
14 x 26	20	17	M3	4	2,2	40	6	97	52	0,039	●
15 x 28	20	17	M3	4	2,2	43	6	90	48	0,044	●
16 x 32	21	17	M4	4	4,9	80	10	149	74	0,067	●
17 x 35	25	21	M4	4	4,9	85	10	112	54	0,090	●
18 x 35	25	21	M4	4	4,9	90	10	106	54	0,087	●
19 x 35	25	21	M4	4	4,9	95	10	100	54	0,083	●
20 x 38	26	21	M5	4	10	164	16	155	82	0,100	●
22 x 40	26	21	M5	4	10	180	16	141	78	0,110	●
24 x 47	32	26	M6	4	17	278	23	146	75	0,200	●
25 x 47	32	26	M6	4	17	289	23	140	75	0,190	●
28 x 50	32	26	M6	6	17	486	35	188	105	0,220	●
30 x 55	32	26	M6	6	17	520	35	175	96	0,270	●
32 x 55	32	26	M6	6	17	555	35	164	96	0,250	●
35 x 60	37	31	M6	8	17	810	46	173	101	0,360	●
38 x 65	37	31	M6	8	17	879	46	159	93	0,430	●
40 x 65	37	31	M6	6	17	925	46	151	93	0,400	●
42 x 75	44	36	M8	6	41	1346	64	170	95	0,670	
45 x 75	44	36	M8	8	41	1442	64	159	95	0,630	
48 x 80	44	36	M8	8	41	2052	85	198	119	0,740	●
50 x 80	44	36	M8	8	41	2137	85	191	119	0,700	●

● Clamping sets available from stock.

¹⁾ The figures mentioned are the maximum screw tightening torques. They can be reduced to a maximum of 40 % of the aforementioned figures, while T, F_{ax}, P_W and P_N being reduced proportionally.

KTR 200 and KTR 201 (self-centering)

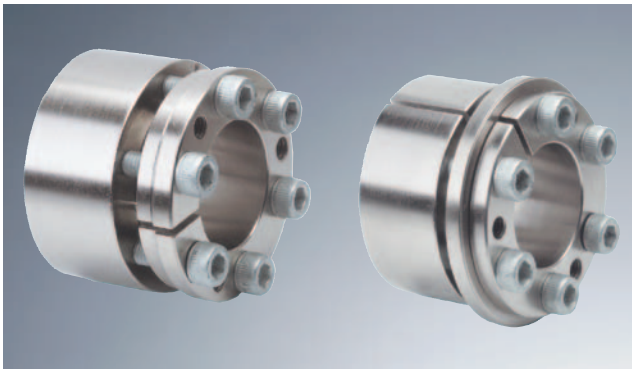

- Clamping element for universal use
- Wide range of applications
- Low-cost solution with average to high torques
- Mounting instructions at www.ktr.com

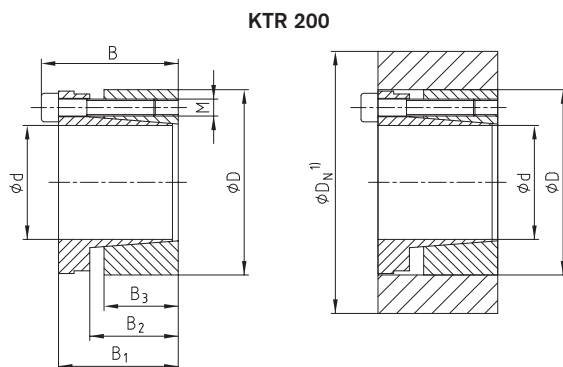

Considerably higher transmittable torque than KTR 201, slight axial displacement of the hub

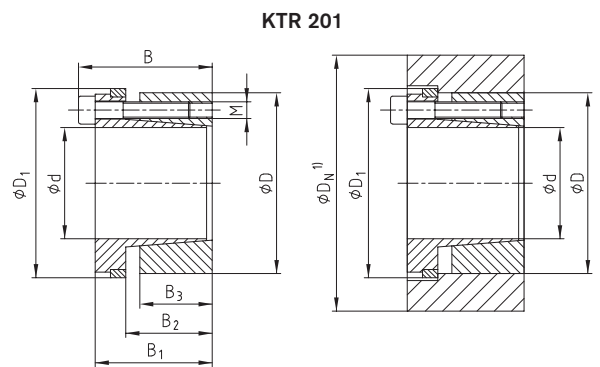

No axial displacement of the hub, but lower transmittable torque than with KTR 200

¹⁾ Dimension D_N : for selection see page 304/305.

Assembly

Clean the contact surfaces of the clamping set as well as the shaft and the hub and afterwards apply thin-bodied oil. Insert the clamping set into the hub fit and push it onto the shaft. Tighten the clamping screws crosswise, evenly and by degrees to the tightening torque T_A mentioned by means of the torque wrench. Check the tightening torque of all clamping screws in the order of arrangement. The figures T and F_{ax} mentioned in the table were calculated for an assembly with oil.

Please note: Oils and greases containing molybdenum disulphide or high-pressure additives, additives of teflon and silicone as well as sliding grease paste reducing the coefficient of friction considerably must not be used. For assembly of the clamping set tapers without oil, the figures mentioned in the table deviate from the calculated figures.

Disassembly

Unscrew the clamping screws. Screw the screws into the forcing thread, tighten them crosswise by degrees and evenly until the rear taper ring is released. For repeated application oil the screws and threads.

Tolerances, surfaces

One accurate turning process is sufficient:

$RZ \leq 16\mu m$

Maximum permissible tolerances:

h8 for the shaft - H8 for the hub

Centering

The clamping elements KTR 200 and KTR 201 are self-centering. The concentricity of the clamping set between shaft and hub is between 0,02 and 0,08 mm.

Ordering example:	KTR 200	40	x	65
	Type	Size of inside diameter d		Size of outside diameter D

KTR 200 and KTR 201 (self-centering) – Technical data

CLAMPEX® – KTR 200 and KTR 201																							
d x D [mm]	Dimensions [mm]					Clamping screws DIN EN ISO 4762 - 12.9 H _{ges.} =0,14				KTR 200								KTR 201					
										Transmittable torque or axial force		Surface pressure between clamping set		Weight [-kg]	Stock programme	Transmittable torque or axial force		Surface pressure between clamping set		Weight [-kg]	Stock programme		
										T [Nm]	F _{ax} [kN]	Shaft P _W [N/mm ²]	Hub P _N [N/mm ²]			T [Nm]	F _{ax} [kN]	Shaft P _W [N/mm ²]	Hub P _N [N/mm ²]				
B	B ₁	B ₂	B ₃	D ₁	M	z number	T _A [Nm] ¹⁾		T [Nm]	F _{ax} [kN]	Shaft P _W [N/mm ²]	Hub P _N [N/mm ²]	Weight [-kg]	Stock programme	T [Nm]	F _{ax} [kN]	Shaft P _W [N/mm ²]	Hub P _N [N/mm ²]	Weight [-kg]	Stock programme			
20 x 47	48	42	31	26	53	M6	6	17	17	513	51	291	124	0,41	●	332	33	178	76	0,42	●		
22 x 47	48	42	31	26	53	M6	6	17	17	564	51	264	124	0,38	●	366	33	162	76	0,39	●		
24 x 50	48	42	31	26	56	M6	6	17	17	616	51	242	116	0,42	●	399	33	149	71	0,43	●		
25 x 50	48	42	31	26	56	M6	6	17	17	641	51	233	116	0,41	●	415	33	143	71	0,42	●		
28 x 55	48	42	31	26	61	M6	6	17	17	718	51	208	106	0,50	●	465	33	127	65	0,51	●		
30 x 55	48	42	31	26	61	M6	6	17	17	769	51	194	106	0,47	●	499	33	119	65	0,48	●		
32 x 60	48	42	31	26	66	M6	8	17	17	1094	68	242	129	0,56	●	709	44	149	79	0,57	●		
35 x 60	48	42	31	26	66	M6	8	17	17	1197	68	222	129	0,53	●	776	44	136	79	0,54	●		
38 x 65	48	42	31	26	71	M6	8	17	17	1299	68	204	119	0,62	●	842	44	125	73	0,63	●		
40 x 65	48	42	31	26	71	M6	8	17	17	1368	68	194	119	0,57	●	886	44	119	73	0,58	●		
42 x 75	59	51	35	30	81	M8	6	41	41	1990	95	222	124	1,01	●	1290	61	136	76	1,02	●		
45 x 75	59	51	35	30	81	M8	6	41	41	2132	95	207	124	0,98	●	1382	61	127	76	0,99	●		
48 x 80	59	51	35	30	86	M8	8	41	41	3033	126	259	155	1,09	●	1965	82	159	95	1,10	●		
50 x 80	59	51	35	30	86	M8	8	41	41	3159	126	248	155	1,07	●	2047	82	152	95	1,08	●		
55 x 85	59	51	35	30	91	M8	8	41	41	3475	126	226	146	1,15	●	2252	82	139	90	1,16	●		
60 x 90	59	51	35	30	96	M8	8	41	41	3791	126	207	138	1,23	●	2456	82	127	85	1,24	●		
65 x 95	59	51	35	30	101	M8	8	41	41	4107	126	191	131	1,32	●	2661	82	117	80	1,33	●		
70 x 110	70	60	45	40	119	M10	8	83	83	7023	201	211	134	2,18	●	4550	130	130	83	2,29	●		
75 x 115	70	60	45	40	124	M10	8	83	83	7524	201	197	129	2,30	●	4875	130	121	79	2,41	●		
80 x 120	70	60	45	40	129	M10	8	83	83	8026	201	185	123	2,44	●	5200	130	113	76	2,56	●		
85 x 125	70	60	45	40	134	M10	10	83	83	10659	251	217	148	2,55	●	6907	163	133	91	2,67	●		
90 x 130	70	60	45	40	139	M10	10	83	83	11286	251	205	142	2,67	●	7313	163	126	87	2,80	●		
95 x 135	70	60	45	40	144	M10	10	83	83	11373	239	186	131	2,80	●	7501	158	116	82	2,93	●		
100 x 145	80	68	52	45	155	M12	8	145	145	14607	292	191	132	3,90	●	9465	189	117	81	4,10	●		
110 x 155	80	68	52	45	165	M12	8	145	145	16068	292	174	123	4,20	●	10411	189	107	76	4,40	●		
120 x 165	80	68	52	45	175	M12	10	145	145	21910	365	199	145	4,50	●	14197	237	122	89	4,72	●		
130 x 180	80	68	52	45	188	M12	12	145	145	28483	438	221	159	5,50	●	18456	284	136	98	5,74	●		
140 x 190	90	76	58	50	199	M14	10	210	230	32023	457	193	142	6,60	●	22726	325	130	95	6,92	●		
150 x 200	90	76	58	50	209	M14	12	210	230	41173	549	216	162	6,90	●	29219	390	145	109	7,24	●		
160 x 210	90	76	58	50	219	M14	12	210	230	43918	549	202	154	7,40	●	31167	390	136	104	7,76	●		
170 x 225	90	76	58	50	234	M14	14	210	230	54440	640	222	168	8,60	●	38634	455	149	113	8,98	●		
180 x 235	90	76	58	50	244	M14	14	210	230	57642	640	210	161	9,10	●	40907	455	141	108	9,50	●		

● Clamping sets available from stock.

¹⁾ These are the maximum screw tightening torques. They can be reduced to a maximum of 40% of the aforementioned figures with T, F_{ax}, P_W and P_N being reduced proportionally.

KTR 203 and KTR 206 (self-centering)

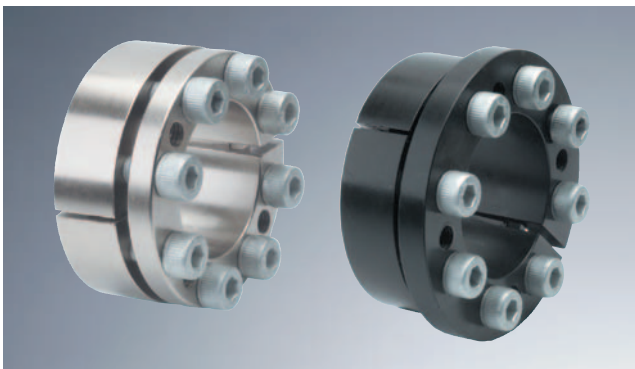

- Clamping set for universal applications
- Short mounting dimensions
- Operation as with KTR 200/201
- Mounting instructions at www.ktr.com

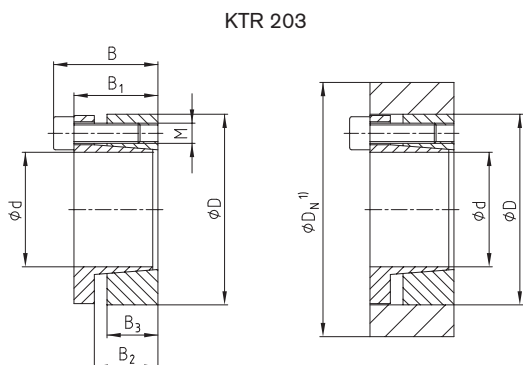

Higher transmittable torque than KTR 206,
slight axial displacement of the hub

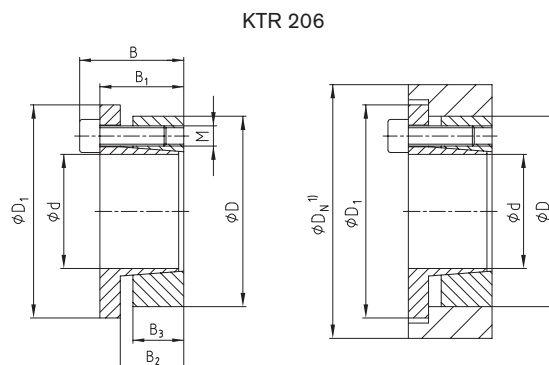

No axial displacement of the hub,
but lower transmittable torque than KTR 203

¹⁾ Dimension D_N : for calculation see page 304/305.

Assembly

Clean the contact surfaces of the clamping set as well as the shaft and the hub and afterwards apply thin-bodied oil. Insert the clamping set into the hub fit and push it onto the shaft. Tighten the clamping screws crosswise, evenly and by degrees to the tightening torque T_A mentioned by means of the torque wrench. Check the tightening torque of all clamping screws in the order of arrangement. The figures T and F_{ax} mentioned in the table were calculated for an assembly with oil.

Please note: Oils and greases containing molybdenum disulphide or high-pressure additives, additives of teflon and silicone as well as sliding grease paste reducing the coefficient of friction considerably must not be used. For assembly of the clamping set tapers without oil, the figures mentioned in the table deviate from the calculated figures.

Disassembly

Unscrew the clamping screws. Screw the screws into the forcing thread, tighten them crosswise by degrees and evenly until the rear taper ring is released. For repeated application oil the screws and threads.

Tolerances, surfaces

One accurate turning process is sufficient:

$RZ \leq 16\mu m$

Maximum permissible tolerances:

h8 for the shaft - H8 for the hub

Centering

The clamping elements KTR 203 and KTR 206 are self-centering. The concentricity of the clamping set between shaft and hub is between 0,02 and 0,08 mm.

Ordering example:	KTR 203	40	x	65
	Type	Size of inside diameter d		Size of outside diameter D

KTR 203 and KTR 206 (self-centering) – Technical data

CLAMPEX® – KTR 203 and KTR 206																						
d x D [mm]	Dimensions [mm]					Clamping screws DIN EN ISO 4762 - 12.9 $\mu_{ges.}=0,14$				Transmittable torque or axial force		KTR 203				KTR 206		KTR 206				
						M	z number	T _A [Nm] ¹⁾		T [Nm]	F _{ax} [kN]	Shaft P _W [N/mm ²]	Hub P _N [N/mm ²]	Weight [-kg]	Stock programme	T [Nm]	F _{ax} [kN]	Shaft P _W [N/mm ²]	Hub P _N [N/mm ²]	Weight [-kg]	Stock programme	
								KTR 203	KTR 206													T [Nm]
20 x 47	34	28	22	17	53	M6	6	14	17	428	43	334	142	0,25	●	332	33	259	110	0,26	●	
22 x 47	34	28	22	17	53	M6	6	14	17	471	43	304	142	0,23	●	366	33	236	110	0,24	●	
24 x 50	34	28	22	17	56	M6	6	14	17	514	43	278	134	0,26	●	399	33	216	104	0,27	●	
25 x 50	34	28	22	17	56	M6	6	14	17	535	43	267	134	0,25	●	415	33	207	104	0,26	●	
28 x 55	34	28	22	17	61,4	M6	6	14	17	599	43	239	121	0,31	●	465	33	185	94	0,32	●	
30 x 55	34	28	22	17	61,4	M6	6	14	17	642	43	223	121	0,29	●	499	33	173	94	0,30	●	
32 x 60	34	28	22	17,5	67	M6	8	14	17	913	57	278	148	0,34	●	709	44	216	115	0,35	●	
35 x 60	34	28	22	17,5	67	M6	8	14	17	999	57	254	148	0,33	●	776	44	198	115	0,34	●	
38 x 65	34	28	22	17,5	72	M6	8	14	17	1084	57	234	137	0,38	●	842	44	182	106	0,39	●	
40 x 65	34	28	22	17,5	72	M6	8	14	17	1141	57	223	137	0,34	●	886	44	173	106	0,35	●	
42 x 75	41	33	25	20	84	M8	8	35	41	2207	105	332	186	0,59	●	1719	82	259	145	0,60	●	
45 x 75	41	33	25	20	84	M8	8	35	41	2364	105	310	186	0,58	●	1842	82	241	145	0,59	●	
48 x 80	41	33,5	24	20	89	M8	8	35	41	2522	105	290	174	0,64	●	1965	82	226	136	0,65	●	
50 x 80	41	33,5	24	20	89	M8	8	35	41	2627	105	279	174	0,63	●	2047	82	217	136	0,64	●	
55 x 85	41	33,5	24	20	91	M8	8	35	41	2890	105	253	164	0,69	●	2252	82	197	128	0,70	●	
60 x 90	41	33,5	24	20	99	M8	8	35	41	3152	105	232	155	0,73	●	2456	82	181	121	0,74	●	
65 x 95	41	33,5	24	20	104	M8	8	35	41	3415	105	214	147	0,79	●	2661	82	167	114	0,80	●	
70 x 110	50	40	29	24	119	M10	8	70	83	5934	170	268	170	1,47	●	4550	130	205	131	1,58	●	
75 x 115	50	40	29	24	124	M10	8	70	83	6358	170	250	163	1,55	●	4875	130	192	125	1,66	●	
80 x 120	50	40	29	24	129	M10	8	70	83	6782	170	234	156	1,65	●	5200	130	180	120	1,77	●	
85 x 125	50	40	29	24	134	M10	10	70	83	9007	212	276	187	1,72	●	6907	163	211	144	1,84	●	
90 x 130	50	40	29	23,7	139	M10	10	70	83	9537	212	260	180	1,81	●	7313	163	200	138	1,94	●	
95 x 135	50	40	29	23,7	144	M10	10	70	83	9611	202	235	166	1,90	●	7501	158	184	129	2,03	●	
100 x 145	56	44	31	25,5	154	M12	8	115	145	11719	234	239	165	2,48	●	9465	189	193	133	2,68	●	
110 x 155	56	44	31	25,5	164	M12	8	115	145	12891	234	217	154	2,66	●	10411	189	176	125	2,86	●	
120 x 165	56	44	31	26	174	M12	9	115	145	15821	264	224	163	2,84	●	12777	213	181	132	3,06	●	
130 x 180	64	52	39	34	189	M12	12	115	145	22853	352	211	152	4,45	●	18456	284	170	123	4,69	●	
140 x 190	68	54	39	34	199	M14	9	185	230	25699	367	205	151	4,62	●	20453	292	163	120	4,94	●	
150 x 200	68	54	39	34	209	M14	10	185	230	30595	408	212	159	4,80	●	24349	325	169	127	5,14	●	
160 x 210	68	54	39	34	219	M14	12	185	230	39161	490	239	182	5,18	●	31167	390	190	145	5,54	●	
170 x 225	78	64	49	44	234	M14	12	185	230	41609	490	225	170	7,33	●	33115	390	179	135	7,71	●	
180 x 235	78	64	49	44	244	M14	12	185	230	44056	490	212	163	7,77	●	35063	390	169	129	8,17	●	
190 x 250	78	64	49	43,5	259	M14	15	185	230	58130	612	196	149	9,7	●	46263	487	156	119	10	●	
200 x 260	78	64	49	43,5	269	M14	15	185	230	61189	612	187	144	10	●	48698	487	149	114	10,3	●	
220 x 285	88	72	57	50	294	M16	12	290	360	74935	681	164	127	13,5	●	59561	542	131	101	14	●	
240 x 305	88	72	57	50	314	M16	15	290	360	102184	852	188	148	14,5	●	81219	677	150	118	15	●	
260 x 325	88	72	57	50	334	M16	18	290	360	132840	1022	209	167	16	●	105585	812	166	133	16,5	●	
280 x 355	102	84	66	60	364	M18	16	400	480	155314	1109	175	138	23,5	●	121616	869	137	108	24	●	
300 x 375	102	84	66	60	384	M18	18	400	480	187209	1248	184	147	25	●	146590	977	144	115	25,5	●	
320 x 405	121	101	81	74	414	M20	18	580	690	260885	1631	183	144	37	●	202849	1268	142	112	38	●	

● Clamping sets available from stock.

¹⁾ These are the maximum screw tightening torques. They can be reduced to a maximum of 40 % of the aforementioned figures with T, F_{ax}, P_W and P_N being reduced proportionally.

KTR 250 (self-centering)



- Clamping set specifically suitable for hubs with a small wall thickness
- Reduction of costs by saving material
- Short assembly times
- Small radial mounting dimensions
- Clamping sets "stainless steel" on request (Please order dimension sheet M367697.)
- Mounting instructions at www.ktr.com

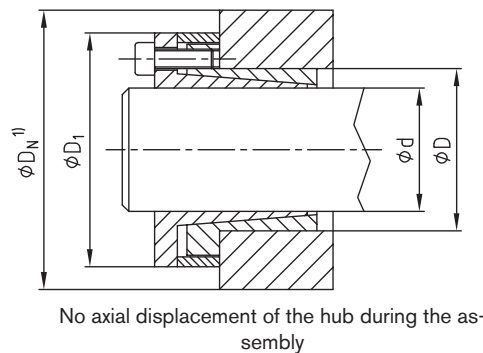
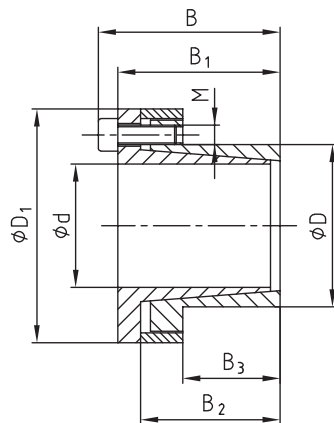

¹⁾ Dimension D_N : for calculation see page 304/305.

Assembly

Clean the contact surfaces of the clamping set as well as the shaft and the hub and afterwards apply thin-bodied oil. Insert the clamping set into the hub fit and push it onto the shaft. Tighten the clamping screws crosswise, evenly and by degrees to the tightening torque T_A mentioned by means of the torque wrench. Check the tightening torque of all clamping screws in the order of arrangement. The figures T and F_{ax} mentioned in the table were calculated for an assembly with oil.

Please note: Oils and greases containing molybdenum disulphide or high-pressure additives, additives of teflon and silicone as well as sliding grease paste reducing the coefficient of friction considerably must not be used. For assembly of the clamping set tapers without oil, the figures mentioned in the table deviate from the calculated figures.

Disassembly

Unscrew the clamping screws. Screw the screws into the forcing thread, tighten them crosswise by degrees and evenly until the rear taper ring is released. For repeated application oil the screws and threads.

Tolerances, surfaces

One accurate turning process is sufficient:

$RZ \leq 16\mu m$

Maximum permissible tolerances:

h8 for the shaft - H8 for the hub

Centering

The clamping element KTR 250 is self-centering. The concentricity of the clamping set between shaft and hub is between 0,02 and 0,08 mm.

Ordering example:	KTR 250	50	x	65
	Type	Size of inside diameter d		Size of outside diameter D

KTR 250 (self-centering) – Technical data

CLAMPEX® – KTR 250														
d x D [mm]	Dimensions [mm]					Clamping screws DIN EN ISO 4762 - 12.9 $\mu_{ges.}=0,14$			Transmittable torque or axial force		Surface pressure between clamping set		Weight [~kg]	Stock pro- gramme
	B	B ₁	B ₂	B ₃	D ₁	M	z number	T _A [Nm] ¹⁾	T [Nm]	F _{ax} [kN]	Shaft P _W [N/mm ²]	Hub P _N [N/mm ²]		
6 x 14	24	21,5	15,5	10	25	M3	4	2	14	5	252	108	0,10	●
8 x 15	29	25	19	11,5	27	M4	3	5	27	7	210	112	0,12	●
9 x 16	30	26	20	14	28	M4	4	5	40	9	207	116	0,15	●
10 x 16	30	26	20	14	29	M4	4	5	46	9	192	120	0,15	●
11 x 18	30	26	20	13,5	32	M4	4	5	49	9	169	103	0,18	●
12 x 18	30	26	20	13,5	32	M4	4	5	55	9	160	106	0,18	●
14 x 23	30	26	20,5	14	38	M4	6	5	96	14	205	125	0,20	●
15 x 24	42	36	27	16	44	M6	4	15	139	19	227	142	0,31	●
16 x 24	42	36	27	16	44	M6	4	15	148	19	213	142	0,30	●
18 x 26	44	38	30	18	47	M6	4	17	199	22	191	132	0,32	●
19 x 27	44	38	30	18	48	M6	4	17	210	22	181	127	0,35	●
20 x 28	44	38	30	18	49	M6	4	17	222	22	172	123	0,36	●
22 x 32	51	45	37	25	54	M6	4	17	244	22	112	77	0,45	●
24 x 34	51	45	37	25	56	M6	4	17	266	22	103	73	0,48	●
25 x 34	51	45	37	25	56	M6	4	17	277	22	99	73	0,50	●
28 x 39	51	45	37	25	61	M6	6	17	465	33	133	95	0,52	●
30 x 41	51	45	37	25	62	M6	6	17	499	33	124	91	0,53	●
32 x 43	51	45	37	25	65	M6	8	17	689	43	150	112	0,58	●
35 x 47	56	50	42	30	69	M6	8	17	776	44	118	88	0,69	●
38 x 50	56	50	42	30	72	M6	8	17	842	44	109	82	0,73	●
40 x 53	56	50	42	30	75	M6	8	17	886	44	103	78	0,80	●
42 x 55	65	57	54	32	78	M8	8	41	1665	80	170	130	0,83	●
45 x 59	73	65	54	40	85	M8	8	41	1842	82	127	97	1,40	●
48 x 62	78	70	59	45	87	M8	8	41	1909	80	103	80	1,42	●
50 x 65	78	70	59	45	92	M8	10	41	2559	102	127	98	1,60	●
55 x 71	83	75	64	50	98	M8	10	41	2815	102	104	81	1,90	●
60 x 77	83	75	64	50	104	M8	10	41	3070	102	95	74	2,05	●
65 x 84	83	75	64	50	111	M8	10	41	3326	102	88	68	2,15	●
70 x 90	101	91	77	60	119	M10	10	83	5688	163	108	84	3,35	●
75 x 95	101	91	77	60	126	M10	10	83	6094	163	101	80	3,60	●
80 x 100	106	96	82	65	131	M10	12	83	7801	195	105	84	3,75	●
85 x 106	106	96	82	65	137	M10	12	83	8288	195	99	79	4,05	●
90 x 112	106	96	82	65	143	M10	15	83	10970	244	116	93	4,32	●
95 x 120	106	96	82	65	153	M10	15	83	11579	244	110	87	4,50	●
100 x 125	114	102	86	65	162	M12	12	145	14197	284	122	98	4,80	●
110 x 140	140	128	109,5	90	180	M12	12	145	15174	276	78	61	6,15	●
120 x 155	140	128	109,5	90	198	M12	12	145	16554	276	71	55	10,14	●
130 x 165	140	128	109,5	90	203	M12	16	145	23911	368	88	69	11,89	●

● Clamping sets available from stock.

¹⁾ These are the maximum screw tightening torques. They can be reduced to a maximum of 40 % of the aforementioned figures with T, F_{ax}, P_W and P_N being reduced proportionally.

²⁾ For different dimensions for clamping sets "stainless steel" please see dimension sheet M367697.

KTR 225 for disk and flange shape drive components (self-centering)



- For the same diameter of the external ring various bore diameters are available
- Only one bore for each size necessary for the hub
- Reduction of components and costs
- Short assembly times
- Mounting instructions at www.ktr.com

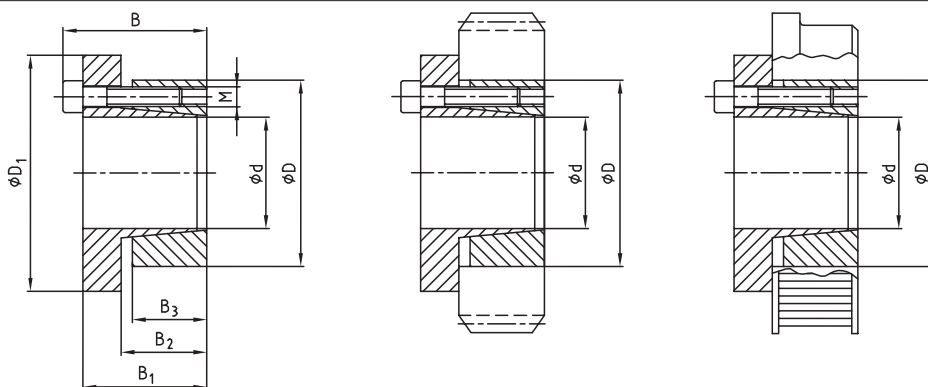

Assembly

Clean the contact surfaces of the clamping set as well as the shaft and the hub and afterwards apply thin-bodied oil. Insert the clamping set into the hub fit and push it onto the shaft. Tighten the clamping screws crosswise, evenly and by degrees to the tightening torque T_A mentioned by means of the torque wrench. Check the tightening torque of all clamping screws in the order of arrangement. The figures T and F_{ax} mentioned in the table were calculated for an assembly with oil.

Please note: Oils and greases containing molybdenum disulphide or high-pressure additives, additives or teflon and silicone as well as sliding grease paste reducing the coefficient of friction considerably must not be used. For assembly of the clamping set taper without oil, the figures mentioned in the table deviate from the calculated figures.

Disassembly

Unscrew the clamping screws. Screw the screws into the pull-off thread, tighten them crosswise by degrees and evenly until the rear taper ring is released. For repeated application oil the screws and threads.

Tolerances, surfaces

One accurate turning process is sufficient:

$RZ \leq 16\mu m$

Maximum permissible tolerances:

h8 for the shaft - H8 for the hub

Axial displacement

During the tightening of the screws there is no axial displacement of the hub towards the shaft.

Centering

The clamping element KTR 225 is self-centering. The concentricity of the clamping set between shaft and hub is between **0,02** and **0,08** mm.

Ordering example:	KTR 225	28	x	65
	Type	Size of inside diameter d		Size of outside diameter D

KTR 225 (self-centering) – Technical data

CLAMPEX® – KTR 225														
d x D [mm]	Dimensions [mm]					Clamping screws DIN EN ISO 4762 - 12.9 $\mu_{ges} = 0,14$			Transmittable torque or axial force		Surface pressure be- tween clamping set		Weight [-kg]	Stock pro- gramme
	B	B ₁	B ₂	B ₃	D ₁	M	z number	TA ¹⁾ [Nm]	T [Nm]	F _{ax} [kN]	Shaft P _W [N/mm ²]	Hub P _H [N/ mm ²]		
14 x 55	38	30	22	17	62	M8	4	41	139	20	263		0,50	●
16 x 55									195	24	244	122	0,49	●
18 x 55									250	28	228		0,48	●
19 x 55	38	30	22	17	62	M8	4	41	278	29	221	122	0,47	●
20 x 55									306	31	214		0,46	●
22 x 55									362	33	203		0,45	●
24 x 55	38	30	22	17	62	M8	4	41	418	35	193	122	0,43	●
25 x 55									446	36	188		0,42	●
28 x 55	38	30	22	17	62	M8	4	41	529	38	177	122	0,39	●
30 x 55									585	39	170		0,37	●
24 x 65									467	39	211		0,66	●
25 x 65	38	30	22	17	72	M8	5	41	500	40	206	129	0,65	●
28 x 65									599	43	193		0,62	●
30 x 65									665	44	186		0,60	●
32 x 65	38	30	22	17	72	M8	5	41	731	46	179	129	0,58	●
35 x 65									830	47	171		0,54	●
38 x 65	38	30	22	17	72	M8	5	41	929	49	164	129	0,50	●
40 x 65									995	50	161		0,47	●
30 x 80									898	60	210		1,08	
32 x 80	41	33	25	20	88	M8	7	41	985	62	202	125	1,05	
35 x 80									1114	64	191		1,01	
38 x 80									1244	65	182		0,97	
40 x 80	41	33	25	20	88	M8	7	41	1331	67	177	125	0,94	●
42 x 80									1417	67	172		0,91	
45 x 80									1547	69	166		0,85	
48 x 80	41	33	25	20	88	M8	7	41	1677	70	161	125	0,79	
50 x 80									1764	71	159		0,75	●

● Clamping sets available from stock.

¹⁾ These are the maximum screw tightening torques. They can be reduced to a maximum of 40 % of the aforementioned figures with T, F_{ax}, P_W and P_H being reduced proportionally.

Assembly with belt drive

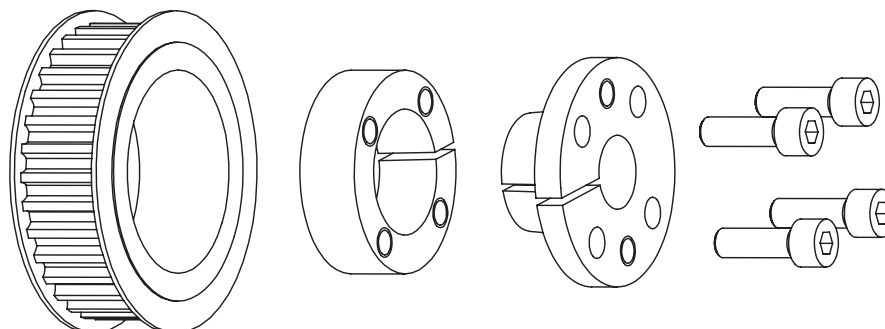

For different shaft diameters only one cylindrical bore dimension is necessary in the pulley in case of KTR 225.

You will find continuously updated data in our online catalogue at www.ktr.com

KTR 400 (self-centering)

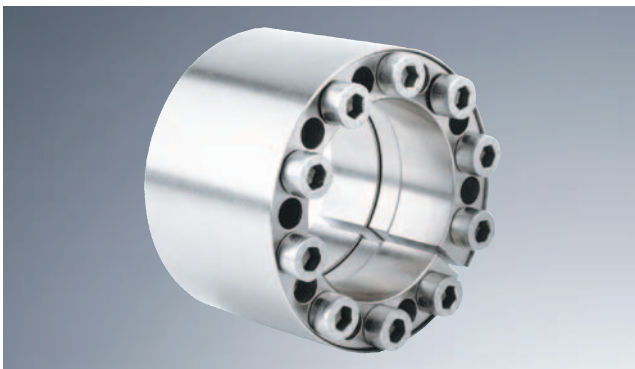

- Clamping set suitable for high loads
- Specifically suitable for vibratory torques
- Typical applications: flywheels, belt drums
- Torque factor
 - 1 off 1 x T
 - 2 off 1,9 x T
 - 3 off 2,7 x T
 - 4 off 3,6 x T
- KTR 402 for shaft Ø 320 mm to Ø 560 mm and high torques, please order dimension sheet M483041.
- Mounting instructions at www.ktr.com

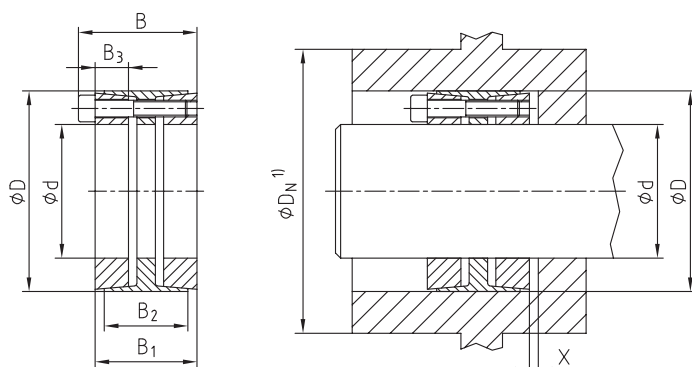

Formula to calculate space x left for disassembly:

$$x = (B1 - B2) / 2$$

¹⁾ Dimension D_N : for calculation see page 304 / 305.

Assembly

Clean the contact surfaces of the clamping set as well as the shaft and the hub and afterwards apply thin-bodied oil. Insert the clamping set into the hub fit and push it onto the shaft. Tighten the clamping screws evenly and crosswise. Here please increase the tightening torque step by step. This must be repeated until reaching the indicated tightening torque with all clamping screws.

Please note: Oils and greases containing molybdenum disulphide or high-pressure additives, additives of teflon and silicone as well as sliding grease paste reducing the coefficient of friction considerably must not be used. For assembly of the clamping set tapers without oil, the figures mentioned in the table deviate from the calculated figures.

Disassembly

Unscrew all clamping screws and screw them into the pull-off threads of the front taper ring. Tighten the screws crosswise by degrees and evenly to half the tightening torque T_A . Afterwards repeat this process to the full tightening torque. As soon as the front taper ring is released, screw the clamping screws into the pull-off threads of the spacer ring in order to release the rear taper ring.

Please note: If the clamping element KTR 400 is reused it has to be made sure that the pull-off threads of the front taper ring and the spacer are in their original position. Here the slots of the front and the back pressure ring and those of the external ring must be flush.

Tolerances, surfaces

One accurate turning process is sufficient:

$$RZ \leq 16\mu\text{m}$$

Maximum permissible tolerances:

h8 for the shaft - H8 for the hub

Axial displacement

During the assembly a slight axial displacement of the hub towards the shaft may arise.

Centering

The clamping element KTR 400 is self-centering. The concentricity of the clamping set between shaft and hub is between **0,02** and **0,08** mm.

Example of installation

Drive of conveyor belt drum

The following conditions should be adhered to as limiting values for CLAMPEX® clamping sets with load by bending: Direction angles α on the contact position shaft-clamping set $\leq 6^\circ$ or maximum shaft bending f_m in the bearing area:

$$f_m \leq l (1/2000 - 1/3000).$$

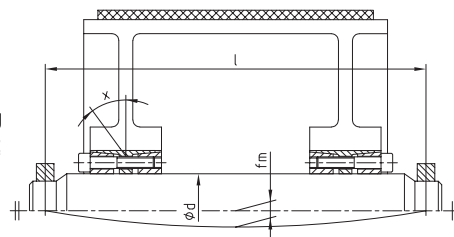

Ordering example:	KTR 400	100	x	145
	Type	Size of inside diameter d		Size of outside diameter D

KTR 400 (self-centering) – Technical data

CLAMPEX® – KTR 400																							
d x D ¹⁾ [mm]		Dimensions [mm]				Standard industrial applications						Applications with components subject to bending and torsion										Weight [-kg]	Stock programme
						Clamping screws DIN EN ISO 4762 - 12.9 H _{ges.} =0,14			Transmittable torque or axial force		Surface pressure between clamp- ing set		Clamping screws DIN EN ISO 4762 - 12.9 H _{ges.} =0,14			Transmittable torque or axial force		Transmit- table bending		Surface pressure between clamp- ing set			
						M	z num- ber	T _A ²⁾ [Nm]	T [Nm]	F _{ax} [kN]	Shaft P _W [N/mm ²]	Hub P _N [N/mm ²]	M	z num- ber	T _A [Nm]	T [Nm]	F _{ax} [kN]	moment Mbperm. [Nm]	Shaft P _W [N/mm ²]	Hub P _N [N/mm ²]			
24 x 50	51	45	41	16	M6	6	17	712	59	205	85	M6	6	14	505	42	420	242	82	0,54			
25 x 50	51	45	41	16	M6	6	17	742	59	197	85	M6	6	14	521	42	437	234	83	0,53			
28 x 55	51	45	41	16	M6	8	17	831	59	176	78	M6	8	14	811	58	490	270	107	0,50			
30 x 55	51	45	41	16	M6	8	17	1187	79	219	103	M6	8	14	856	57	525	255	109	0,47	●		
32 x 60	51	45	41	16	M6	8	17	1266	79	205	95	M6	8	14	899	56	560	242	101	0,77			
35 x 60	51	45	41	16	M6	8	17	1385	79	187	95	M6	8	14	960	55	612	224	102	0,71	●		
38 x 65	51	45	41	16	M6	10	17	1880	99	216	109	M6	10	14	1350	71	665	252	100	1,25			
40 x 65	51	45	41	16	M6	10	17	1979	99	205	109	M6	10	14	1404	70	700	242	101	1,21	●		
42 x 75	51	45	41	16	M8	8	41	3071	146	289	140	M8	8	35	2326	111	735	323	141	1,16			
45 x 75	51	45	41	16	M8	8	41	3290	146	269	140	M8	8	35	2463	109	787	304	142	1,08	●		
48 x 80	70	62	58	23	M8	8	41	3518	147	196	93	M8	8	35	2377	99	1708	212	101	1,45	●		
50 x 80	70	62	58	23	M8	8	41	3664	147	188	93	M8	8	35	2267	91	1779	196	97	1,38	●		
55 x 85	70	62	58	23	M8	8	41	4031	147	171	88	M8	8	35	2408	88	1957	182	93	1,49	●		
60 x 90	70	62	58	23	M8	10	41	5497	183	196	103	M8	10	35	3447	115	2134	203	107	1,60	●		
65 x 95	70	62	58	23	M8	10	41	5955	183	181	98	M8	10	35	3633	112	2312	190	103	1,70	●		
70 x 110	86	76	70	28	M10	10	83	10182	291	219	111	M10	10	69	6619	189	3659	222	113	3,12	●		
75 x 115	86	76	70	28	M10	10	83	10910	291	204	107	M10	10	69	6950	185	3920	210	110	3,29	●		
80 x 120	86	76	70	28	M10	12	83	13964	349	230	122	M10	12	69	9200	230	4181	231	123	3,46	●		
85 x 125	86	76	70	28	M10	12	83	14837	349	216	118	M10	12	69	9613	226	4443	220	120	3,64	●		
90 x 130	86	76	70	28	M10	12	83	15710	349	204	113	M10	12	69	10008	222	4704	210	116	3,81	●		
95 x 135	86	76	70	28	M10	12	83	16583	349	193	109	M10	12	69	10383	219	4965	201	113	3,98	●		
100 x 145	110	98	92	35	M12	12	145	25415	508	214	112	M12	12	120	16527	331	8587	219	115	6,12	●		
110 x 155	110	98	92	35	M12	12	145	27956	508	195	105	M12	12	120	17658	321	9445	203	110	6,62	●		
120 x 165	110	98	92	35	M12	14	145	35581	593	208	115	M12	14	120	22948	382	10304	214	119	7,12	●		
130 x 180	128	114	108	41	M14	12	230	45333	697	193	106	M14	12	190	28502	438	15350	201	110	9,98	●		
140 x 190	128	114	108	41	M14	14	230	56957	814	209	117	M14	14	190	36719	525	16531	215	120	10,62	●		
150 x 200	128	114	108	41	M14	16	230	69743	930	223	127	M14	16	190	45796	611	17712	226	129	11,26	●		
160 x 210	128	114	108	41	M14	16	230	74392	930	209	121	M14	16	190	47959	599	18893	215	124	11,91	●		
170 x 225	162	146	136	52	M16	14	355	96123	1131	189	109	M16	14	295	59316	698	32060	196	113	17,66	●		
180 x 235	162	146	136	52	M16	15	355	116317	1292	203	119	M16	15	295	67564	751	33946	198	116	18,49	●		
190 x 250	162	146	136	52	M16	16	355	122779	1292	193	112	M16	16	295	76340	804	35831	200	116	21,39	●		
200 x 260	162	146	136	52	M16	16	355	129241	1292	183	108	M16	16	295	78946	789	37717	192	113	22,36	●		
220 x 285	162	146	136	52	M16	18	355	177706	1616	208	123	M16	18	295	98472	895	41489	195	115	26,59	●		
240 x 305	162	146	136	52	M16	20	355	200324	1777	210	126	M16	20	295	120113	1001	45261	198	119	28,70	●		
260 x 325	166	150	134	52	M16	21	355	233398	1795	185	122	M16	21	295	145842	1122	48311	202	126	31,23			
280 x 355	197	177	165	66	M20	18	690	336303	2402	192	121	M20	18	580	210027	1500	81312	200	126	46,77			
300 x 375	197	177	165	66	M20	20	690	400360	2669	199	127	M20	20	580	253018	1687	87120	206	132	49,72			
320 x 405	197	177	165	66	M20	21	690	448404	2803	196	124	M20	21	580	281947	1762	92928	203	128	60,52			
340 x 425	197	177	165	66	M20	22	690	499116	2936	193	123	M20	22	580	312383	1838	98736	201	128	63,86			
360 x 455	224	202	190	76	M22	21	930	627940	3489	188	119	M22	21	780	389170	2162	138624	196	124	86,78			
380 x 475	224	202	190	76	M22	22	930	694389	3655	186	119	M22	22	780	429232	2259	146325	195	125	91,04			
400 x 495	224	202	190	76	M22	24	930	797384	3987	193	125	M22	24	780	498899	2494	154027	201	130	95,30			
420 x 515	224	202	190	76	M22	24	930	837254	3987	184	120	M22	24	780	515180	2453	161728	193	126	100			
440 x 535	224	202	190	76	M22	24	930	877123	3987	176	116	M22	24	780	530636	2412	169429	186	123	105			
460 x 555	224	202	190	76	M22	24	930	916992	3987	168	111	M22	24	780	545266	2371	177131	180	119	109			
480 x 575	224	202	190	76	M22	28	930	1116338	4651	188	125	M22	28	780	691858	2883	184832	196	131	114			
500 x 595	224	202	190	76	M22	28	930	1162852	4651	180	121	M22	28	780	710371	2841	192533	190	128	119			
520 x 615	224	202	190	76	M22	30	930	1295750	4984	186	126	M22	30	780	799984	3077	200235	195	132	112,5			
540 x 635	224	202	190	76	M22	30	930	1345586	4984	179	122	M22	30	780	819613	3036	207936	189	129	128			
560 x 655	224	202	190	76	M22	32	930	1488451	5316	184	126	M22	32	780	915876	3271	215637	193	132	131			
580 x 675	224	202	190	76	M22	32	930	1541610	5316	178	122	M22	32	780	936621	3230	223339	188	129	136			
600 x 695	224	202	190	76	M22	33	930	1644606	5482	177	122	M22	33	780	998037	3327	231040	188	130	139			

● Clamping sets available from stock.

¹⁾ External ring from size 400 x 495 without slot.

²⁾ These are the maximum screw tightening torques. They can be reduced to a maximum of 40 % of the aforementioned figures with T, F_{ax}, P_W and P_N being reduced proportionally.

KTR 130 and KTR 131 (self-centering)

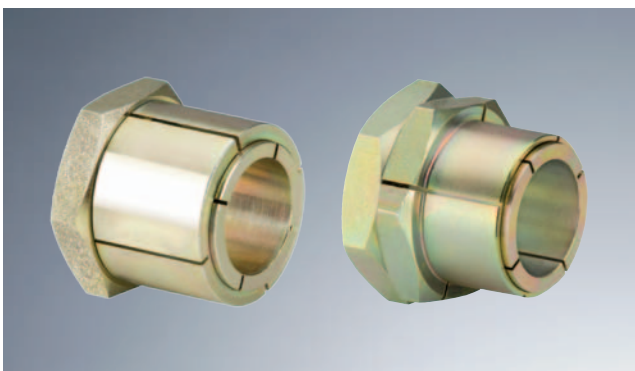

- Corrosion-protected surface
- Assembly and disassembly by means of central clamping nut
- Self-centering
- Shaft diameters from 5 mm to 50 mm
- Tolerance h8/H8 for shaft and hub
- KTR 131: Hexagon locking nuts for clamping on easily torsionable shafts
- Mounting instructions at www.ktr.com

KTR 130

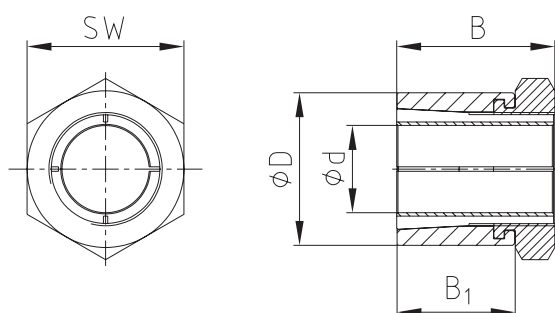

KTR 131

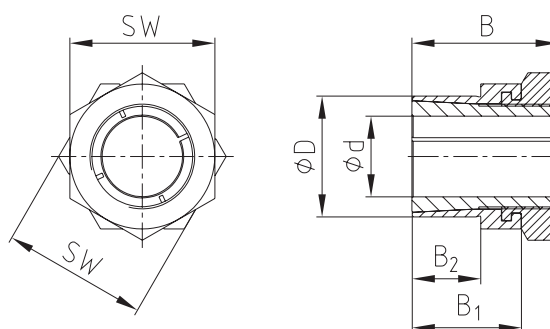

Assembly Clean the contact surfaces of the clamping set as well as the shaft and the hub and afterwards apply thin-bodied oil. Unscrew the hexagon nut. Insert the clamping set into the hub fit and push onto the shaft. Lightly tighten the hexagon nut and align the clamping set with the hub element. Afterwards tighten the hexagon nut or hexagon nut along with the counter nut to the tightening torque T_A mentioned by means of a dynamometric screwdriver. The figures T and F_{ax} mentioned in the table were calculated for an assembly with oil.

Please note: Oils and greases containing molybdenum disulphide or high-pressure additives, additives of teflon and silicone as well as sliding grease paste reducing the coefficient of friction considerably must not be used. For an assembly of the clamping set tapers free from oil the figures mentioned in the table deviate from the calculated figures.

Disassembly

Unscrew the hexagon nut. Turn the hexagon nut left until the clamping set can be moved on the shaft. Afterwards remove the unscrewed clamping set between shaft and hub. In case of repeated use, please lubricate the hexagon nut and thread.

Tolerances, surfaces

One accurate turning process is sufficient:

$RZ \leq 16\mu\text{m}$

Maximum permissible tolerances:

h8 for the shaft - H8 for the hub

Axial displacement

During the process of tightening the hexagon nut the hub opposite to the shaft is displaced axially.

Centering

The clamping element KTR 130 is self-centering. The concentricity of the clamping set between shaft and hub is between **0,02** and **0,08** mm.

Ordering example:	KTR 130	18	x	35
	Type	Size of inside diameter d		Size of outside diameter D

KTR 130 and KTR 131 (self-centering) – Technical data

CLAMPEX® – KTR 130										
d x D [mm]	Dimensions [mm]		Hexagon nut		Transmittable torque or axial force			Surface pressure between clamping sets		Weight [~kg]
	B	B ₁	Width across flats SW	T _A [Nm]	T [Nm]	F _{ax} [kN]	Shaft P _W [N/mm ²]	Hub P _N [N/mm ²]		
5 x 14	19	15	14	10	10,1	4,0	264	96	0,018	
6 x 14	19	15	14	10	12,1	4,0	220	96	0,017	
8 x 16	22	17	17	17	23,4	5,8	179	91	0,024	
9 x 20	24	19	22	35	43,2	9,7	248	112	0,042	
10 x 20	24	19	22	35	48,6	9,7	223	112	0,045	
12 x 22	24	19	22	44	65,3	10,9	206	117	0,048	
14 x 26	28	22	27	65	93,0	13,3	178	99	0,081	
15 x 26	28	22	27	65	99,0	13,3	166	99	0,076	
16 x 26	28	22	27	65	106	13,3	156	99	0,071	
18 x 35	36	27	36	161	223	24,8	224	125	0,197	
19 x 35	36	27	36	161	235	24,8	212	125	0,191	
20 x 35	36	27	36	161	248	24,8	201	125	0,181	
22 x 42	41	30	46	250	349	31,8	197	110	0,342	
24 x 42	41	30	46	250	381	31,8	180	110	0,321	
25 x 42	41	30	46	250	397	31,8	173	110	0,309	
30 x 47	44	33	50	355	605	40,4	162	110	0,372	
32 x 55	51	38	55	490	764	47,8	166	102	0,627	
35 x 55	51	38	55	490	836	47,8	151	102	0,566	
40 x 62	58	43	65	800	1329	66,5	152	98	0,835	
45 x 65	63	48	65	900	1605	71,0	142	98	0,855	
48 x 75	73	58	75	1290	2227	92,0	121	77	1,470	
50 x 75	73	58	75	1290	2320	92,0	116	77	1,380	

CLAMPEX® – KTR 131											
d x D [mm]	Dimensions [mm]			Hexagon nut/counter nut		Transmittable torque or axial force			Surface pressure between clamping set		Weight [~kg]
	B	B ₁	B ₂	Width across flats SW	T _A [Nm]	T [Nm]	F _{ax} [kN]	Shaft P _W [N/mm ²]	Hub P _N [N/mm ²]		
5 x 12	19	15	9	14	10	10,1	4,0	264	119	0,016	
6 x 12	19	15	9	14	10	12,1	4,0	220	119	0,015	
8 x 14	22	17	11	17	17	23,4	5,8	179	121	0,021	
10 x 18	24	19	12	22	35	48,6	9,7	221	127	0,044	
12 x 20	24	19	12	22	44	65,3	10,9	206	128	0,044	
14 x 24	28	22	15	27	65	93,0	13,3	178	107	0,077	
15 x 24	28	22	15	27	65	99,0	13,3	166	107	0,072	
16 x 24	28	22	15	27	65	106	13,3	156	107	0,068	
18 x 30	36	27	17	36	161	223	24,8	224	145	0,176	
19 x 30	36	27	17	36	161	235	24,8	212	145	0,175	
20 x 30	36	27	17	36	161	248	24,8	201	145	0,162	
22 x 38	41	30	20	46	250	349	31,8	197	122	0,337	
24 x 38	41	30	20	46	250	381	31,8	180	122	0,313	
25 x 38	41	30	20	46	250	397	31,8	173	122	0,303	
30 x 42	44	33	23	50	355	605	40,4	162	123	0,342	
32 x 50	51	38	28	55	490	764	47,8	166	112	0,549	
35 x 50	51	38	28	55	490	836	47,8	151	112	0,494	

KTR 100 (not self-centering)



- „Typical clamping set“
- Axial fastening of the hub
- Torque factor
 - 1 off 1 x T
 - 2 off 1,9 x T
 - 3 off 2,7 x T
 - 4 off 3,6 x T
- KTR 114 for higher torques (Please order dimension sheet M448436.)
- Mounting instructions at www.ktr.com

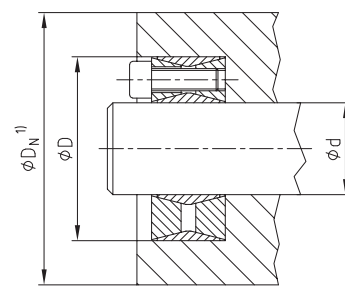
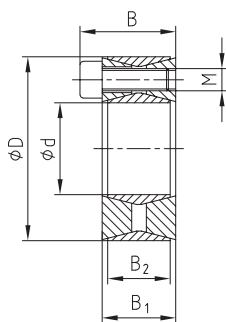

Assembly with centering of hub

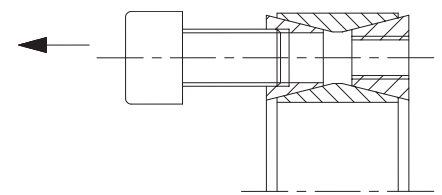

Accessory thread for disassembly

¹⁾ Dimension D_N : for calculation see page 304/305.

Assembly

Clean the contact surfaces of the clamping set as well as the shaft and the hub and afterwards apply thin-bodied oil. Insert the clamping set into the hub fit and push it onto the shaft. Tighten the chromated screws until the internal ring is in contact with the shaft and the external ring is in contact with the hub. Afterwards tighten the clamping screws crosswise by degrees and evenly until the tightening torque T_A mentioned in the table is achieved. The figures T and F_{ax} mentioned in the table were calculated for an assembly with oil.

Please note: Oils and greases containing molybdenum disulphide additives, additives of teflon and silicone as well as sliding grease paste reducing the coefficient of friction considerably must not be used. For an assembly of the clamping set tapers free from oil the figures mentioned in the table deviate from the calculated figures.

Disassembly

Unscrew all clamping screws. In normal cases the clamping element releases automatically. Otherwise lightly strike with a hammer onto the detached screws in order to push back the rear taper ring. By using the accessory threads the detached clamping set can be pulled-off.

Please note: The accessory threads for the disassembly only have approx. 3 - 5 supporting turns and are not cut. These are no threads for forcing screws.

Tolerances, surfaces

One accurate turning process is sufficient:
 $RZ \leq 16\mu m$

Maximum permissible tolerances:
h11 for the shaft - H11 for the hub

Axial displacement

During the tightening of the screws there is no axial displacement of the hub towards the shaft.

Centering

The clamping element KTR 100 is not self-centering. The concentricity of the hub towards the shaft merely depends on the fit and the length of the pilot.

Ordering example:	KTR 100	50	x	80
	Type	Size of inside diameter d		Size of outside diameter D

KTR 100 (not self-centering) – Technical data

CLAMPEX® – KTR 100													
d x D [mm]	Dimensions [mm]			Clamping screws DIN EN ISO 4762 - 12.9 $\mu_{ges.}=0,14$			Transmittable torque or axial force		Surface pressure between clamping set		Weight [-kg]	Stock programme	
	B	B ₁	B ₂	M	z number	T _A [Nm] ¹⁾	T [Nm]	F _{ax} [kN]	Shaft P _W [N/mm ²]	Hub P _N [N/mm ²]			
18 x 47	26	20	17	M6	8	15	240	27	289	111	0,24	●	
19 x 47	26	20	17	M6	8	15	254	27	274	111	0,24	●	
20 x 47	26	20	17	M6	8	15	267	27	260	111	0,23	●	
22 x 47	26	20	17	M6	8	15	294	27	237	111	0,23	●	
24 x 50	26	20	17	M6	8	15	320	27	217	104	0,26	●	
25 x 50	26	20	17	M6	8	15	334	27	208	104	0,25	●	
28 x 55	26	20	17	M6	12	15	560	40	279	142	0,30	●	
30 x 55	26	20	17	M6	12	15	600	40	260	142	0,29	●	
32 x 60	26	20	17	M6	12	15	641	40	244	130	0,34	●	
35 x 60	26	20	17	M6	12	15	701	40	223	130	0,32	●	
38 x 65	26	20	17	M6	15	15	951	50	257	150	0,36	●	
40 x 65	26	20	17	M8	15	15	1001	50	244	150	0,34	●	
42 x 75	32	24	20	M8	12	37	1506	72	283	159	0,60	●	
45 x 75	32	24	20	M8	12	37	1614	72	264	159	0,57	●	
48 x 80	32	24	20	M8	12	37	1721	72	248	149	0,60	●	
50 x 80	32	24	20	M8	12	37	1793	72	238	149	0,60	●	
55 x 85	32	24	20	M8	15	37	2465	90	270	175	0,63	●	
60 x 90	32	24	20	M8	15	37	2690	90	248	165	0,69	●	
65 x 95	32	24	20	M8	15	37	2914	90	229	156	0,73	●	
70 x 110	38	28	24	M10	15	70	4992	143	282	179	1,26	●	
75 x 115	38	28	24	M10	15	70	5349	143	263	171	1,33	●	
80 x 120	38	28	24	M10	15	70	5705	143	246	164	1,40	●	
85 x 125	38	28	24	M10	15	70	6092	143	232	158	1,49	●	
90 x 130	38	28	24	M10	15	70	6418	143	219	152	1,53	●	
95 x 135	38	28	24	M10	18	70	8130	171	249	175	1,62	●	
100 x 145	44	32	26	M12	15	127	10881	218	278	191	2,01	●	
110 x 155	44	32	26	M12	15	127	11969	218	252	179	2,15	●	
120 x 165	44	32	26	M12	16	127	13927	232	247	179	2,35	●	
130 x 180	50	38	34	M12	20	127	18860	290	218	157	3,51	●	
140 x 190	50	38	34	M12	22	127	22341	319	222	164	3,85	●	
150 x 200	50	38	34	M12	24	127	26113	348	226	170	4,07	●	
160 x 210	50	38	34	M12	26	127	30175	377	230	175	4,30	●	
170 x 225	58	44	38	M14	22	195	35710	420	216	163	5,78	●	
180 x 235	58	44	38	M14	24	195	41248	458	222	170	6,05	●	
190 x 250	66	52	46	M14	28	195	50796	535	203	154	8,25	●	
200 x 260	66	52	46	M14	30	195	57289	573	206	159	8,65	●	
220 x 285	72	56	50	M16	26	300	74838	680	205	158	11,22	●	
240 x 305	72	56	50	M16	30	300	94202	785	217	171	12,20	●	
260 x 325	72	56	50	M16	34	300	115659	890	227	182	13,20	●	
280 x 355	84	66	60	M18	32	410	139261	995	196	155	19,20	●	
300 x 375	84	66	60	M18	36	410	167860	1119	206	165	20,50	●	
320 x 405	98	78	72	M20	36	590	240190	1501	216	171	29,60	●	
340 x 425	98	78	72	M20	36	590	255201	1501	203	163	31,10	●	
360 x 455	112	90	84	M22	36	790	328186	1823	200	158	42,20	●	
380 x 475	112	90	84	M22	36	790	346419	1823	189	152	44,00	●	
400 x 495	112	90	84	M22	36	790	364651	1823	180	145	46,00	●	
420 x 515	112	90	84	M22	40	790	371953	1771	196	160	50,00	●	
440 x 545	130	102	96	M24	40	1000	453797	2063	188	152	64,60	●	
460 x 565	130	102	96	M24	40	1000	467548	2033	180	146	67,40	●	
480 x 585	130	102	96	M24	42	1000	512270	2134	181	148	71,00	●	
500 x 605	130	102	96	M24	44	1000	559025	2236	182	150	72,60	●	
520 x 630	130	102	96	M24	45	1000	603344	2321	179	148	80,00	●	
540 x 650	130	102	96	M24	45	1000	626549	2321	172	143	82,00	●	
560 x 670	130	102	96	M24	48	1000	683027	2439	177	148	85,00	●	
580 x 690	130	102	96	M24	50	1000	736897	2541	178	150	88,00	●	
600 x 710	130	102	96	M24	50	1000	773517	2578	172	145	91,00	●	

● Clamping sets available from stock.

¹⁾ These are the maximum screw tightening torques. They can be reduced by a maximum of 40 % of the aforementioned figures, with T, F_{ax}, P_W and P_N being reduced proportionally.

KTR 150 (not self-centering)



- Clamping set for small radial mounting dimensions
- Increase of torque by using several clamping sets in a series
- Mounting instructions at www.ktr.com

Before tightening of screws

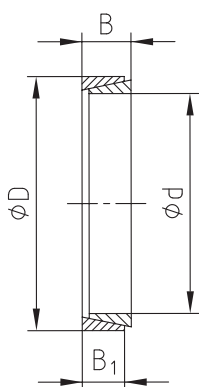

Assembly 1

Clamping on hub side

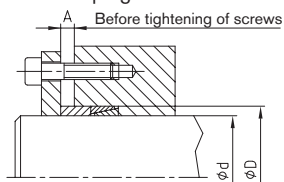

Assembly 2

Clamping on shaft side

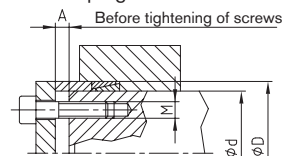

Up to 4 clamping sets can be used in a series.

The torques are increased as follows:

- | | |
|---------------------|--|
| 1 clamping element | $T = T_{\text{catalogue}} \times 1,00$ |
| 2 clamping elements | $T = T_{\text{catalogue}} \times 1,55$ |
| 3 clamping elements | $T = T_{\text{catalogue}} \times 1,85$ |
| 4 clamping elements | $T = T_{\text{catalogue}} \times 2,02$ |

Recommended pressure flanges*
(dimensions see table below)

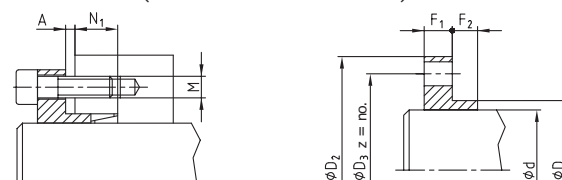

Assembly

Clean the contact surfaces of the clamping set as well as the shaft and the hub and afterwards apply thin-bodied oil. Insert the clamping set, distance ring and clamping flange, tighten the clamping screws crosswise by degrees and evenly until the screw tightening torque defined for the corresponding screw size is achieved. The figures T and F_{ax} mentioned in the table were calculated for an assembly with oil.

Please note: Oils and greases containing molybdenum or high-pressure additives, additives of teflon and silicone as well as sliding grease paste reducing the coefficient of friction considerably must not be used. For an assembly of the clamping set tapers free from oil the figures mentioned in the table deviate from the calculated figures.

Disassembly

Unscrew all clamping screws. In normal cases the clamping element releases automatically. Otherwise lightly strike with a hammer onto the hub or shaft.

Tolerances, surfaces

One accurate turning process is sufficient:

$RZ \leq 16\mu\text{m}$

Maximum permissible tolerances:

shaft h6 - hub H7 ($\leq \varnothing 38 \text{ mm}$)

shaft h8 - hub H8 ($> \varnothing 38 \text{ mm}$)

Recommended dimensions of pressure flange* for 1 to 4 clamping elements KTR 150																																	
$d^{H8} \times D_{g7}$	9,1 x 12	10,1 x 13	12,1 x 15	13,1 x 16	14,1 x 18	15,1 x 19	16,2 x 20	17,2 x 21	18,2 x 22	19,2 x 24	20,2 x 25	22,2 x 26	24,2 x 28	25,2 x 30	28,2 x 32	30,2 x 35	32,2 x 36	35,2 x 40	36,2 x 42	38,2 x 44	40,2 x 45	42,2 x 48	45,2 x 52	48,2 x 55	50,2 x 57	55,2 x 62	56,2 x 64	60,2 x 68	63,2 x 71	65,2 x 73	70,2 x 79	71,2 x 80	75,2 x 84
D ₂	36	37	39	40	44	45	46	47	48	52	53	54	56	58	60	63	64	68	70	72	78	81	85	88	90	95	102	106	109	111	117	118	122
D ₃	28	29	31	32	35	36	37	38	39	42	43	44	45	48	50	53	54	58	60	62	65	68	72	75	77	82	86	90	93	95	101	102	106
M	M4	M4	M4	M4	M5	M5	M5	M5	M5	M6	M6	M6	M6	M6	M6	M6	M6	M6	M6	M6	M8	M8	M8	M8	M8	M8	M10	M10	M10	M10	M10	M10	M10
z	4	4	4	4	4	4	4	4	4	4	4	4	4	4	4	4	5	6	6	6	4	4	6	8	8	8	6	6	6	6	8	8	8
Tightening torque [Nm]	2,9	2,9	2,9	2,9	6	6	6	6	6	10	10	10	10	10	10	10	10	10	10	10	25	25	25	25	25	25	49	49	49	49	49	49	49
F ₁	5,5	5,5	5,5	5,5	7	7	7	7	7	8	8	8	8	8	8	8	8	8	8	8	10,5	10,5	10,5	10,5	10,5	10,5	13	13	13	13	13	13	13
F ₂	7	7	7	7	8,5	8,5	8,5	8,5	8,5	8,5	8,5	8,5	8,5	8,5	8,5	8,5	8,5	8,5	8,5	9,5	9,5	9,5	9,5	9,5	9,5	9,5	10,5	10,5	10,5	10,5	10,5	10,5	10,5
N ₁	The hollow depth results from the number of clamping elements (max. 4-off) and the dimensions = $F_2 - A$.																																

* not part of the components delivered by KTR

Ordering example:	KTR 150	60	x	68
	Type	Size of inside diameter d		Size of outside diameter D

KTR 150 (not self-centering) – Technical data

CLAMPEX® – KTR 150															
d x D [mm]	Dimensions [mm]		Distance dimension A [mm]				Clamping force required for clamping screws $\mu_{ges.}=0,14$			Transmittable torque or axial force		Surface pressure between clamping set		Weight [-kg]	Stock programme
	B	B ₁	Clamping elements				P _O [N]	P _S [N]	P _A = P _O + P _S [N]	T [Nm]	F _{ax} [kN]	Shaft P _W [N/mm ²]	Hub P _N [N/mm ²]		
			1	2	3	4									
6 x 9	4,5	3,7	2,5	2,5	3,0	4,0	**	3000	3000	2	0,67	80	53	0,0012	●
7 x 10	4,5	3,7	2,5	2,5	3,0	4,0	**	5300	5300	4	1,19	121	85	0,0014	●
8 x 11	4,5	3,7	2,5	2,5	3,0	4,0	**	5600	5600	5	1,25	112	82	0,0015	●
9 x 12	4,5	3,7	2,5	2,5	3,0	4,0	7947	6653	14600	7	1,50	119	89	0,0017	●
10 x 13	4,5	3,7	2,5	2,5	3,0	4,0	7063	8937	16000	10	2,00	143	110	0,0018	●
12 x 15	4,5	3,7	2,5	2,5	3,0	4,0	7808	8192	16000	11	1,80	110	88	0,0021	●
13 x 16	4,5	3,7	2,5	2,5	3,0	4,0	7007	9693	16700	14	2,20	120	97	0,0023	●
14 x 18	6,3	5,3	3,5	3,5	4,5	5,5	11957	14043	26000	22	3,10	112	87	0,0049	●
15 x 19	6,3	5,3	3,5	3,5	4,5	5,5	12106	14894	27000	25	3,30	111	88	0,0053	●
16 x 20	6,3	5,3	3,5	3,5	4,5	5,5	12478	14522	27000	26	3,20	102	91	0,0055	●
17 x 21	6,3	5,3	3,5	3,5	4,5	5,5	11678	16822	28500	32	4,10	120	90	0,0058	●
18 x 22	6,3	5,3	3,5	3,5	4,5	5,5	14630	18370	33000	37	3,70	102	94	0,0061	●
19 x 24	6,3	5,3	3,5	3,5	4,5	5,5	14186	18814	33000	40	4,20	111	88	0,0078	●
20 x 25	6,3	5,3	3,5	3,5	4,5	5,5	13339	19661	33000	44	4,40	110	88	0,0082	●
22 x 26	6,3	5,3	3,5	3,5	4,5	5,5	13689	20311	34000	50	4,50	103	87	0,0072	●
24 x 28	6,3	5,3	3,5	3,5	4,5	5,5	8676	25324	34000	68	5,70	118	101	0,0080	●
25 x 30	6,3	5,3	3,5	3,5	4,5	5,5	10190	26810	37000	75	6,00	120	100	0,0100	●
28 x 32	6,3	5,3	3,5	3,5	4,5	5,5	11275	28725	40000	90	6,40	115	101	0,009	●
30 x 35	6,3	5,3	3,5	3,5	4,5	5,5	10211	29789	40000	100	6,70	111	95	0,012	●
32 x 36	6,3	5,3	3,5	3,5	4,5	5,5	6487	33513	40000	120	7,50	117	104	0,010	●
35 x 40	7	6,0	3,5	3,5	4,5	5,5	9147	40853	50000	160	9,10	115	101	0,017	●
36 x 42	7	6,0	3,5	3,5	4,5	5,5	12910	43690	56600	176	9,80	120	103	0,020	●
38 x 44	7	6,0	3,5	3,5	4,5	5,5	15317	44683	60000	190	10,00	116	100	0,021	●
40 x 45	8	6,6	3,5	4,5	5,5	6,5	18614	51386	70000	230	11,50	116	103	0,023	●
42 x 48	8	6,6	3,5	4,5	5,5	6,5	14678	55322	70000	260	12,40	118	104	0,028	●
45 x 52	10	8,6	3,5	4,5	5,5	6,5	32549	77451	110000	390	17,30	119	103	0,042	●
48 x 55	10	8,6	3,5	4,5	5,5	6,5	29942	80058	110000	430	17,90	115	100	0,045	●
50 x 57	10	8,6	3,5	4,5	5,5	6,5	25995	84005	110000	470	18,80	116	102	0,047	●
55 x 62	10	8,6	3,5	4,5	5,5	6,5	25759	94241	120000	580	21,10	118	105	0,050	●
56 x 64	12	10,4	3,5	4,5	5,5	7,0	33227	117773	151000	738	26,40	120	105	0,067	●
60 x 68	12	10,4	3,5	4,5	5,5	7,0	34887	125113	160000	840	28,00	119	105	0,072	●
63 x 71	12	10,4	3,5	4,5	5,5	7,0	30510	132490	163000	934	29,70	120	107	0,077	●
65 x 73	12	10,4	3,5	4,5	5,5	7,0	22513	137487	160000	1000	30,80	121	108	0,079	●
70 x 79	14	12,2	3,5	5,0	6,5	7,5	34033	165967	200000	1300	37,10	115	102	0,110	●
71 x 80	14	12,2	3,5	5,0	6,5	7,5	36043	174957	211000	1390	39,20	120	106	0,120	●
75 x 84	14	12,2	3,5	5,0	6,5	7,5	41267	178733	220000	1500	40,00	116	104	0,130	●
80 x 91	17	15,0	4,0	6,0	6,5	8,0	65412	234588	300000	2100	52,50	116	102	0,190	●
85 x 96	17	15,0	4,0	6,0	6,5	8,0	54414	257586	312000	2450	57,60	120	106	0,200	●
90 x 101	17	15,0	4,0	6,0	6,5	8,0	51900	268100	320000	2700	60,00	118	105	0,220	●
95 x 106	17	15,0	4,0	6,0	6,5	8,0	52145	287855	340000	3060	64,40	120	107	0,230	●
100 x 114	21	18,7	5,0	6,0	7,0	9,0	64660	375340	440000	4200	84,00	119	105	0,380	●
110 x 124	21	18,7	5,0	6,0	7,0	9,0	100658	349342	450000	4300	78,20	101	89	0,410	●
120 x 134	21	18,7	5,0	6,0	7,0	9,0	80192	379808	460000	5100	85,00	100	90	0,450	●
130 x 148	28	25,3	5,0	7,0	9,0	11,0	93177	556823	650000	8100	124,60	101	88	0,850	●
140 x 158	28	25,3	6,0	7,0	9,0	11,0	89967	600033	690000	9400	134,30	101	89	0,910	●
150 x 168	28	25,3	6,0	7,0	9,0	11,0	64644	655356	720000	11000	146,70	103	92	0,970	●
160 x 178	28	25,3	6,0	7,0	9,0	11,0	80303	774697	855000	13870	173,40	114	102	1,020	●
170 x 191	33	30,0	7,0	9,0	10,0	12,0	128166	973834	1102000	18525	217,90	113	101	1,500	●
180 x 201	33	30,0	7,0	9,0	10,0	12,0	142494	1057506	1200000	21300	236,70	116	104	1,580	●
190 x 211	33	30,0	7,0	9,0	10,0	12,0	111751	1138249	1250000	24200	254,70	119	107	1,680	●
200 x 224	38	34,8	7,0	9,0	11,0	13,0	182475	1407525	1590000	31500	315,00	120	107	2,320	●
210 x 234	38	34,8	7,0	9,0	11,0	13,0	100300	1489700	1590000	34761	331,10	121	109	2,450	●
220 x 244	38	34,8	7,0	9,0	11,0	13,0	117900	1552100	1670000	37941	344,90	120	109	2,490	●
230 x 257	43	39,5	7,0	10,0	12,0	14,0	168900	1851100	2020000	47307	411,90	121	108	3,380	●
240 x 267	43	39,5	7,0	10,0	12,0	14,0	160700	1929300	2090000	51449	428,70	121	109	3,520	●
250 x 280	48	44,0	7,0	10,0	12,0	16,0	191000	2239000	2430000	52245	418,00	121	108	4,680	●
260 x 290	48	44,0	7,0	10,0	13,0	16,0	182500	2328500	2511000	56506	434,70	121	108	4,820	●
270 x 300	48	44,0	7,0	10,0	13,0	16,0	178000	2422000	2600000	61036	452,10	121	109	4,940	●
280 x 313	53	49,0	7,0	11,0	14,0	17,0	207800	2792200	3000000	72971	521,20	121	108	6,270	●
290 x 323	53	49,0	7,0	11,0	14,0	17,0	220700	2889300	3110000	77740	536,10	121	108	6,500	●
300 x 333	53	49,0	7,0	11,0	14,0	17,0	215000	2990000	3205000	83224	554,80	121	109	6,700	●
320 x 360	65	59,0	10,0	15,0	20,0	25,0	292000	3848000	4140000	114246	714,00	121	108	10,90	●
340 x 380	65	59,0	10,0	15,0	20,0	25,0	275000	4085000	4360000	128863	758,00	121	108	11,50	●
360 x 400	65	59,0	10,0	15,0	20,0	25,0	260000	4320000	4580000	141292	801,60	121	109	12,20	●
380 x 420	65	59,0	10,0	15,0	20,0	25,0	270000	4570000	4840000	161122	848,00	121	109	12,80	●
400 x 440	65	59,0	10,0	15,0	20,0	25,0	260000	4800000	5060000	178138	890,70	121	110	13,50	●

● Clamping sets available from stock or in short term.

** Design with slot

Other sizes on request.

P_O = setting force
P_S = clamping force
P_A = total force

Calculation

For a properly working CLAMPEX® shaft-hub-connection the following technical details should be taken into account. Please contact us in case you have tolerances different from the table below.

CLAMPEX® – Tolerances, surface roughness and concentricity						
Type	d [mm]	dw [mm]	Shaft diameter tolerance	Diameter of hub bore tolerance	Surface roughness [µm]	Concentricity (applies for the clamping set only)
KTR 250	-	-	h8	H8	Rz ≤ 16	0,02 - 0,08
KTR 200	-	-	h8	H8	Rz ≤ 16	0,02 - 0,08
KTR 201	-	-	h8	H8	Rz ≤ 16	0,02 - 0,08
KTR 203	-	-	h8	H8	Rz ≤ 16	0,02 - 0,08
KTR 206	-	-	h8	H8	Rz ≤ 16	0,02 - 0,08
KTR 225	-	-	h8	H8	Rz ≤ 16	0,02 - 0,08
KTR 100	-	-	h11	H11	Rz ≤ 16	1)
KTR 105	-	-	h9	H9	Rz ≤ 16	0,02 - 0,08
KTR 150	-	-	h6	H7	Rz ≤ 6	1)
KTR 150	up to 38	-	h8	H8	Rz ≤ 6	1)
KTR 400	bigger than 38	-	h8	H8	Rz ≤ 16	0,02 - 0,08
KTR 620	-	13-150 > 160	H7/h6 > H7/g6	H7/f7	Rz ≤ 16	0,02 - 0,08
KTR 603	-	18 - 30	j6	H6	Rz ≤ 16	0,02 - 0,08
KTR 603	-	31 - 50	h6	H6	Rz ≤ 16	0,02 - 0,08
KTR 603	-	51 - 80	g6	H6	Rz ≤ 16	0,02 - 0,08
KTR 603	-	81 - 500	g6	H7	Rz ≤ 16	0,02 - 0,08

¹⁾ Depending on the centering of the hub or shafts or the drive component and accuracy of assembly, respectively.

Fatigue strength and shape stability of components loaded under torsion and bending

The stress concentration figures β_k , for the clamping elements, are worked out similar to those of hydraulic fittings. The stress concentration is dependent upon the load, the material and the clamping set type. Stress concentration factor on request.

Resulting torque T_R

The transmittable torque $T \approx T_R$ always has to exceed the highest torque peak T_B which may arise in the connection positions. The torque peaks arising during the acceleration of electric motors have to be considered.

$$T \approx T_R \geq \sqrt{T_B^2 + (F_a \cdot d / 2)^2} \quad [\text{Nm}]$$

Transmittable axial force F_{ax}

The maximum transmittable axial force F_{ax} which is mentioned in the tables has to be reduced accordingly in case of additional torque transmission.

$$F_{ax} = 2 \cdot T / d \quad [\text{kN}]$$

Calculation of the outside diameter of the hub D_N

The required outside diameter of the hub D_N depends on the cross section of the hub, the shape of the hub and the apparent yield point of the hub material. In order to facilitate the calculation the table on page 297 shows some figures by the help of which D_N can be determined.

Example:

Shaft diameter $d = 50 \text{ mm}$

Hub material: GGG 40

Apparent yield point of material $\sigma_{0,2} = 250 \text{ N/mm}^2$

Selected: CLAMPEX® clamping set KTR 100

with $d \times D = 50 \text{ mm} \times 80 \text{ mm}$ and $P_N = 149 \text{ N/mm}^2$ page 293

→ approximate value from table on page 297: $P_N = 150 \text{ N/mm}^2$ selected design

see page 297. $C = 0,8$ (value C of hub shape)

→ figure as per table 1,69

→ $D_N = D \times 1,69 = 80 \text{ mm} \times 1,69 = \underline{135,20 \text{ mm}}$

Outside diameters of hubs which cannot be calculated based on the table are calculated with the following formula:

$$D_N \geq D \cdot \sqrt{(\sigma_{N0,2} + P_N \cdot C) / (\sigma_{N0,2} - P_N \cdot C)} \quad [\text{mm}]$$

Tangential tension on the inside diameter of hub

$$\sigma_{tN} \approx P_N \cdot (1 + C_N^2) / (1 - C_N^2) \cdot C \quad [\text{N/mm}^2]$$

For clamping connections with hollow shafts the required inside diameter of the hollow shaft d_{iW} is calculated with the following formula:

$$d_{iW} \leq d \cdot \sqrt{(\sigma_{W0,2} - 2 \cdot P_W \cdot 0,8) / \sigma_{W0,2}} \quad [\text{mm}]$$

Tangential tension on the inside diameter of shaft

$$\sigma_{tW} \approx 2 \cdot P_W / (C_W^2 - 1) \quad [\text{N/mm}^2]$$

$\sigma_{N0,2}$	=	Apparent yield point of the hub material [N/mm ²]
C	=	Value C of hub shape (see illustration on page 305)
P_N	=	Surface pressure of clamping set/hub arising [N/mm ²]
d	=	Inside diameter of the clamping set [mm]
D	=	Outside diameter of the clamping set [mm]
D_N	=	Minimum outside diameter of hub [mm]
T	=	Transmittable torque [Nm]
T_R	=	Resulting transmittable torque [Nm]
T_B	=	Operating torque to be transmitted [Nm]
L/L1	=	Hub length [mm]

$\sigma_{W0,2}$	=	Apparent yield point of the shaft material [N/mm ²]
P_W	=	Surface pressure of clamping set/shaft arising [N/mm ²]
C_W	=	d_{iW}/d
C_N	=	D/D_N
F_a	=	Axial force arising during operation [N]
F_{ax}	=	Maximum transmittable axial force [kN]
FV	=	Prestress [N]
PO	=	Setting force for clamping set [N]
PS	=	Clamping force for clamping set [N]
PA	=	$P_O + P_S$ = Total power for clamping set [N]

Calculation of hubs

Table of screws						
Dimension M	Prestress F_V and tightening torque T_A with $\mu_{total} = 0,14$					
	Prestress F_V [N]			Tightening torque T_A [Nm]		
	8.8	10.9	12.9	8.8	10.9	12.9
M3	2210	3110	3730	1,34	1,89	2,25
M4	3900	5450	6550	2,9	4,1	4,9
M5	6350	8950	10700	6	8,5	10
M6	9000	12600	15100	10	14	17
M8	16500	23200	27900	25	35	41
M10	26200	36900	44300	49	69	83
M12	38300	54000	64500	86	120	145
M14	52500	74000	88500	135	190	230
M16	73000	102000	123000	210	295	355
M18	88000	124000	148000	290	405	485
M20	114000	160000	192000	410	580	690
M22	141000	199000	239000	550	780	930
M24	164000	230000	276000	710	1000	1200
M27	215000	302000	363000	1050	1500	1800
M30	262000	368000	442000	1450	2000	2400

**Mounting conditions of clamping set
Value C of hub shape**

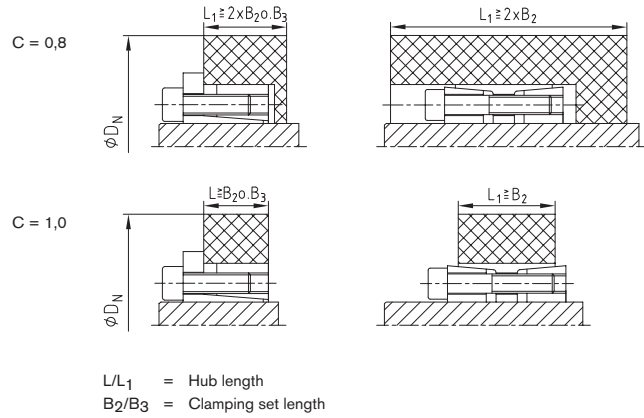

Selection table for the calculation of the required outside diameter of hub D_N												
Surface pressure between clamping set and hub		Average apparent yield point of material σ 0,2 in N/mm ² (more accurate stiffness data, depending on the diameter, as per details mentioned by the manufacturer)										
		150	180	200	220	250	270	300	350	400	450	600
P_N [N/mm ²]	Hub shape Value C	Hub materials										
		GG 20	GG 25 GS 38	GG 30 GTS 35	GS 45 ST 37-2	GGG 40 GS 52 AlCuMgPb	ST 50-2 C 35	GGG 50 GS 60 ST 52-3	GGG 60 GS 62 C 45	GGG 70 GS 70 C 60	Tempering steel	Tempering steel
60	C = 0,8	1,39	1,30	1,24	1,23	1,22	1,20	1,18	1,15	1,12	1,11	1,08
	C = 1,0	1,52	1,42	1,36	1,32	1,28	1,25	1,22	1,18	1,16	1,14	1,10
65	C = 0,8	1,44	1,35	1,30	1,28	1,24	1,22	1,20	1,16	1,14	1,12	1,09
	C = 1,0	1,60	1,45	1,40	1,35	1,30	1,28	1,24	1,20	1,18	1,16	1,12
70	C = 0,8	1,48	1,38	1,34	1,30	1,25	1,23	1,20	1,18	1,15	1,13	1,10
	C = 1,0	1,65	1,50	1,45	1,40	1,34	1,30	1,26	1,22	1,20	1,17	1,13
75	C = 0,8	1,52	1,42	1,36	1,32	1,28	1,25	1,22	1,18	1,16	1,14	1,11
	C = 1,0	1,74	1,55	1,48	1,42	1,36	1,33	1,30	1,25	1,20	1,18	1,13
80	C = 0,8	1,58	1,45	1,39	1,35	1,30	1,27	1,24	1,20	1,18	1,15	1,11
	C = 1,0	1,81	1,61	1,53	1,46	1,39	1,36	1,31	1,26	1,22	1,20	1,14
85	C = 0,8	1,63	1,49	1,42	1,38	1,32	1,29	1,26	1,22	1,19	1,16	1,12
	C = 1,0	1,90	1,67	1,57	1,50	1,42	1,39	1,34	1,28	1,24	1,21	1,15
90	C = 0,8	1,69	1,53	1,46	1,40	1,34	1,31	1,28	1,23	1,20	1,18	1,13
	C = 1,0	2,00	1,73	1,62	1,54	1,46	1,41	1,36	1,30	1,26	1,22	1,16
95	C = 0,8	1,75	1,57	1,49	1,43	1,37	1,34	1,30	1,25	1,21	1,19	1,14
	C = 1,0	2,11	1,80	1,68	1,59	1,49	1,44	1,39	1,32	1,27	1,24	1,17
100	C = 0,8	1,81	1,61	1,53	1,46	1,39	1,36	1,31	1,26	1,22	1,20	1,14
	C = 1,0	2,24	1,87	1,73	1,63	1,53	1,48	1,41	1,34	1,29	1,25	1,18
105	C = 0,8	1,88	1,66	1,56	1,50	1,42	1,38	1,33	1,28	1,24	1,21	1,15
	C = 1,0	2,38	1,95	1,79	1,68	1,56	1,51	1,44	1,36	1,31	1,27	1,19
110	C = 0,8	1,96	1,71	1,60	1,53	1,44	1,40	1,35	1,29	1,25	1,22	1,16
	C = 1,0	2,55	2,04	1,86	1,73	1,60	1,54	1,47	1,38	1,33	1,28	1,20
115	C = 0,8	2,04	1,76	1,64	1,56	1,47	1,43	1,37	1,31	1,26	1,23	1,17
	C = 1,0	2,75	2,13	1,93	1,79	1,64	1,58	1,50	1,41	1,34	1,30	1,21
120	C = 0,8	2,13	1,81	1,69	1,60	1,50	1,45	1,39	1,33	1,28	1,24	1,18
	C = 1,0	3,00	2,24	2,00	1,84	1,69	1,61	1,53	1,43	1,36	1,31	1,22
125	C = 0,8	2,24	1,87	1,73	1,63	1,53	1,48	1,41	1,34	1,29	1,25	1,18
	C = 1,0	3,32	2,35	2,08	1,91	1,73	1,65	1,56	1,45	1,38	1,33	1,24
130	C = 0,8	2,35	1,93	1,78	1,67	1,56	1,50	1,44	1,36	1,30	1,27	1,19
	C = 1,0	3,74	2,49	2,17	1,97	1,78	1,69	1,59	1,48	1,40	1,35	1,25
135	C = 0,8	2,48	2,00	1,83	1,71	1,59	1,53	1,46	1,38	1,32	1,28	1,20
	C = 1,0	4,36	2,65	2,27	2,04	1,83	1,73	1,62	1,50	1,42	1,36	1,26
140	C = 0,8	2,63	2,07	1,88	1,75	1,62	1,55	1,48	1,39	1,33	1,29	1,21
	C = 1,0	5,39	2,83	2,38	2,12	1,88	1,78	1,66	1,53	1,44	1,38	1,27
145	C = 0,8	2,80	2,15	1,94	1,80	1,65	1,58	1,50	1,41	1,35	1,30	1,22
	C = 1,0	7,68	3,05	2,50	2,21	1,94	1,82	1,69	1,55	1,46	1,40	1,28
150	C = 0,8	3,00	2,24	2,0	1,84	1,69	1,61	1,53	1,43	1,36	1,31	1,23
	C = 1,0	-	3,32	2,65	2,30	2,00	1,87	1,73	1,58	1,48	1,41	1,29
155	C = 0,8	3,25	2,33	2,06	1,89	1,72	1,65	1,55	1,45	1,38	1,33	1,23
	C = 1,0	-	3,66	2,80	2,40	2,06	1,92	1,77	1,61	1,51	1,43	1,30
160	C = 0,8	3,55	2,43	2,13	1,94	1,76	1,67	1,58	1,47	1,39	1,34	1,24
	C = 1,0	-	4,12	3,00	2,52	2,13	1,98	1,81	1,64	1,53	1,45	1,31
165	C = 0,8	3,96	2,55	2,21	2,00	1,80	1,71	1,60	1,49	1,41	1,35	1,25
	C = 1,0	-	4,80	3,23	2,65	2,21	2,04	1,86	1,67	1,55	1,47	1,33

KTR 200 with torsionally flexible ROTEX® coupling

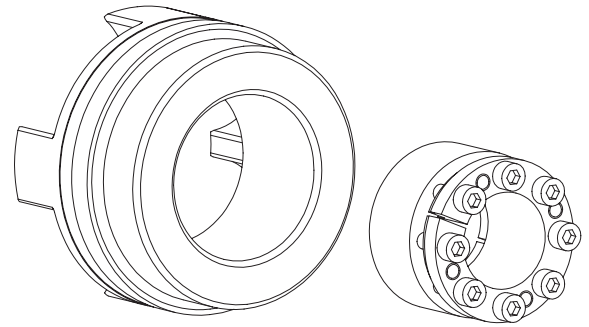
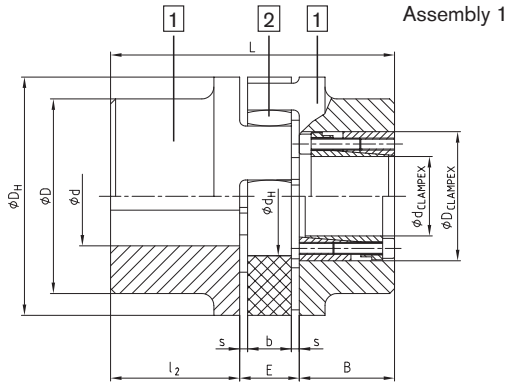

Assembly 2

KTR 200 with torsionally flexible ROTEX® coupling															
ROTEX® Size	Pilot bore Ød [mm]	Hub material	Dimensions of CLAMPEX® KTR 200 [mm]				Dimensions of ROTEX® coupling [mm]								
			Maximum KTR clamping set d x D	Transmittable torques and axial force		B	l ₁	E	s	b	D _H	D	D ₁	d _H	L
				T [Nm]	F _{ax} [kN]										
42	x	Steel part 1	30 x 55	769	51	48	50	26	3,0	20	95	-	95	46	Length L > l ₁ + E + B (clamping set)
48	x		35 x 60	1197	68	48	56	28	3,5	21	105	-	105	51	
55	x		45 x 75	2132	95	59	65	30	4,0	22	120	-	120	60	
65	x		45 x 75	2132	95	59	75	35	4,5	26	135	115	-	68	
75	x		50 x 80	3159	126	59	85	40	5,0	30	160	135	-	80	
90	x	GGG40 part 1	65 x 95	4107	126	59	100	45	5,5	34	200	160	-	100	
100	45		65 x 95	4107	126	59	110	50	6,0	38	225	180	-	113	
110	58		70 x 110	7023	201	70	120	55	6,5	42	255	200	-	127	
125	58		80 x 120	8026	201	70	140	60	7,0	46	290	230	-	147	
140	56		95 x 135	11373	239	66	155	65	7,5	50	320	255	-	165	
160	78	110 x 155	16068	292	80	175	75	9,0	57	370	290	-	190		
180	80	120 x 135	21910	365	80	195	85	10,5	64	420	325	-	220		

CLAMPEX® – KTR 200																	
d x D [mm]	B [mm]	Transmittable torques and axial force		Clamping screws DIN EN ISO 4762 12.9		d x D [mm]	B [mm]	Transmittable torque and axial force		Clamping screws DIN EN ISO 4762 12.9		d x D [mm]	B [mm]	Transmittable torque and axial force		Clamping screws DIN EN ISO 4762 12.9	
		T [Nm]	F _{ax} [kN]	z x M	T _A [Nm]			T [Nm]	F _{ax} [kN]	z x M	T _A [Nm]			T [Nm]	F _{ax} [kN]	z x M	T _A [Nm]
20 x 47	48	513	51	6 x M6	17	38 x 65	48	1299	68	8 x M6	17	65 x 95	59	4107	126	8 x M8	41
22 x 47	48	564	51	6 x M6	17	40 x 65	48	1368	68	8 x M6	17	70 x 110	70	7023	201	8 x M10	83
24 x 50	48	616	51	6 x M6	17	42 x 75	59	1990	95	6 x M8	41	75 x 115	70	7524	201	8 x M10	83
25 x 50	48	641	51	6 x M6	17	45 x 75	59	2132	95	6 x M8	41	80 x 120	70	8026	201	8 x M10	83
28 x 55	48	718	51	6 x M6	17	48 x 80	59	3033	126	8 x M8	41	85 x 125	70	10659	251	10 x M10	83
30 x 55	48	769	51	6 x M6	17	50 x 80	59	3159	126	8 x M8	41	90 x 130	70	11286	251	10 x M10	83
32 x 60	48	1094	68	8 x M6	17	55 x 85	59	3475	126	8 x M8	41	95 x 135	66	11373	239	10 x M10	83
35 x 60	48	1197	68	8 x M6	17	60 x 90	59	3791	126	8 x M8	41	Other data see on page 288					

Other coupling combinations

RADEX®-N NANA 1 with external clamping set KTR 620 and KTR 603

KTR 620

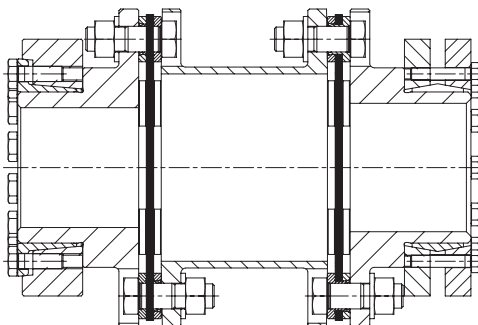

KTR 603

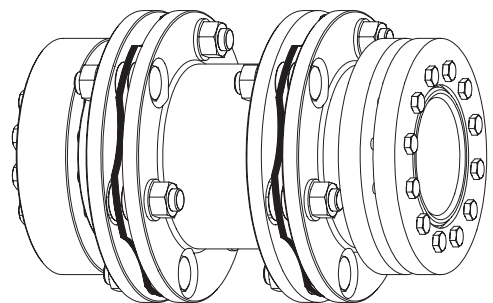

Series on request

SPH Clamping sleeve

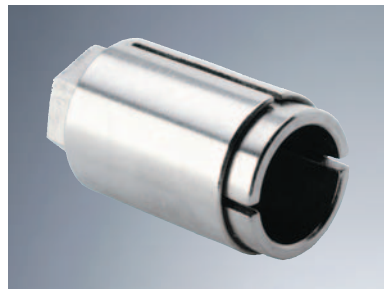

Self-centering

- Fast assembly and disassembly via one screw only
- Suitable for small hub dimensions
- Applications: sprockets, pulleys that are assembled to the shaft end
- Please order our dimension sheet M548658

SPB Clamping sleeve



Self-centering

- Assembly via a central nut
- Suitable for small hub dimensions
- Applications: medical equipment, measuring and control technology, small gearboxes
- Please order our dimension sheet M548677

KTR 401

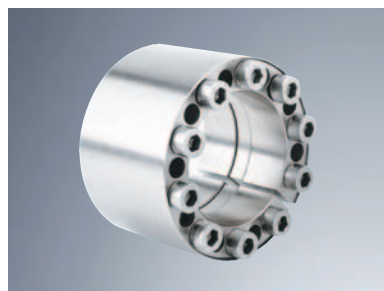

Self-centering, short design

- Clamping set suitable for high loads
- Specifically suitable for vibratory torques
- Typical applications: flywheels, belt drums
- Smaller dimensions than with KTR 400
- Please order our dimension sheet M367699

KTR 125 and KTR 125.1



KTR 125

Not self-centering,
Short design

KTR 125.1

Self-centering,
Long design

- Clamping set for applications with low demands
- Very easy assembly
- Please order our dimension sheet M367700

KTR 700

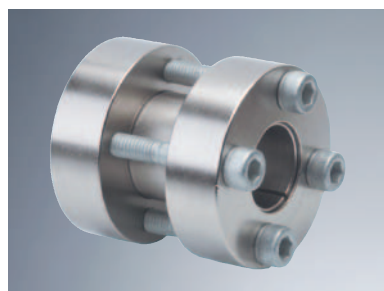

Rigid coupling

- Rigid, backlash-free torque transmission
- Well-aligned, bending and torsionally stiff shaft connection
- Shaft misalignment cannot be compensated
- Please order our dimension sheet M380931

Large screw connections to be assembled easily and quickly



- Use of common dynamometric screwdrivers (up to approx. 100 Nm) even with big screws, e. g. M42 thread.
- Benefits with costs (easy and quick assembly or disassembly, respectively, no need for special tools).
- Optimum load of screws, because they are only loaded with extension (no torsional load like with usual screw connections).
- Ideal for narrow assemblies (e. g. gearbox housings), since it is not necessary to use large tools.
- For screw property classes 8.8 and 10.9.
- Mounting instructions at www.ktr.com

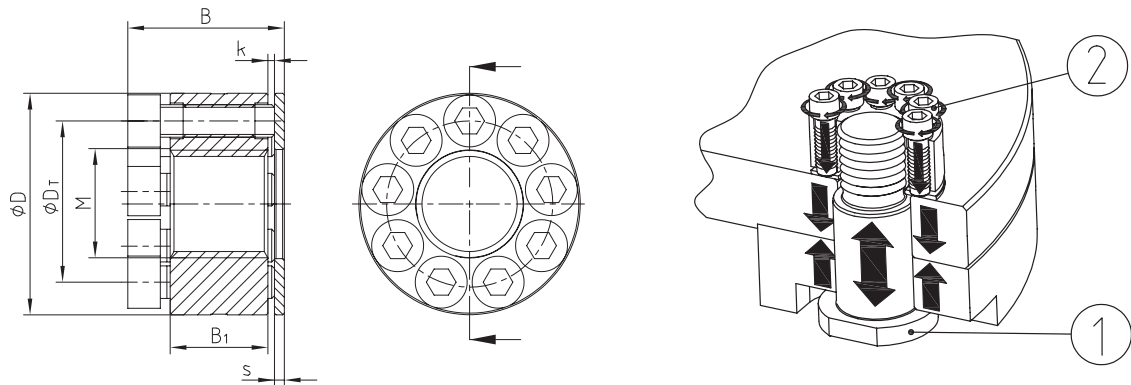

Clamping nut

KTR clamping nuts													
Size	Dimensions [mm]						Pressure screw pos. 2		Property class 8.8 screw pos. 1		Property class 10.9 screw pos. 1		
	D	DT	B	B ₁	s	k	DIN EN ISO 4762	number	Tightening torque * [Nm]	Prestress [N]	Tightening torque * [Nm]	Prestress [N]	
M24 x 3,0	52	39	36,0	20	3,0	1 - 2	M8	8	21	174000	30	249000	
M27 x 3,0	57	42	41,0	25	3,0	1 - 2	M8	9	24	224000	30	280000	
M30 x 3,5	65	48	43,0	25	3,0	1 - 2	M10	8	41	274000	60	401000	
M33 x 3,5	68	51	48,0	30	3,0	1 - 2	M10	9	45	338000	60	451000	
M36 x 4,0	80	58	50,0	30	3,0	1 - 2	M12	8	71	396000	105	586000	
M42 x 4,5	86	64	55,0	35	3,0	1 - 2	M12	10	78	544000	105	732000	
M48 x 5,0	90	72	60,0	40	3,0	1 - 2	M12	11	94	721000	105	806000	
M52 x 5,0	100	79	66,5	42	4,5	1 - 2	M12	13	95	862000	105	952000	
M56 x 5,5	108	83	75,5	45	4,5	1 - 2	M16	9	210	1001000	250	1192000	
M60 x 5,5	112	86	80,5	48	4,5	1 - 2	M16	10	215	1139000	250	1325000	
M64 x 6,0	120	92	84,0	52	8,0	1 - 2	M16	11	225	1311000	250	1457000	
M72 x 6,0	142	107	98,0	58	8,0	1 - 2	M20	10	400	1696000	490	2077000	
M80 x 6,0	164	122	103,0	64	8,0	1 - 2	M20	12	420	2137000	490	2493000	

* each screw pos. 2

Use on a 100 kNm test bench bottle

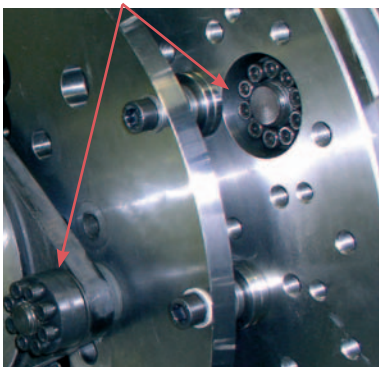

Use of couplings for wind power stations

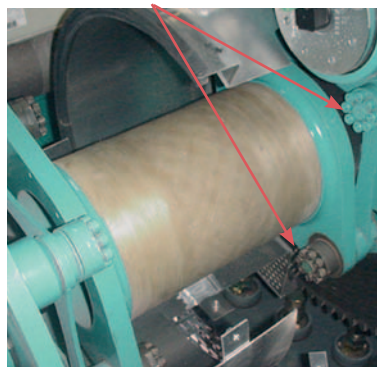

Also available as a complete unit including set screw



Ordering example:

KTR clamping nut	M33 x 3,5
Description	Size

Type G and GD according to DIN 808 with plain bearing



- Suitable for every application in the range of general engineering up to a maximum speed of 1000 r
- Type G precision single joint
- Type GD precision double joint
- Maximum articulation angle 45° for each joint
- Bearings designed as plain bearings
- Available with finish bore H7 – on request with keyway, hexagon bore or square bore
- Also available as clamping hub

Precision single joint G

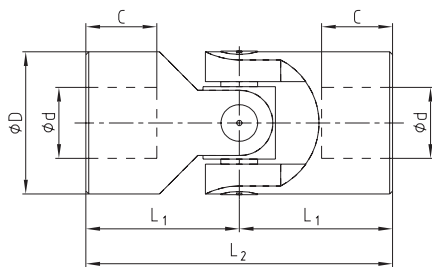

Precision double joint GD

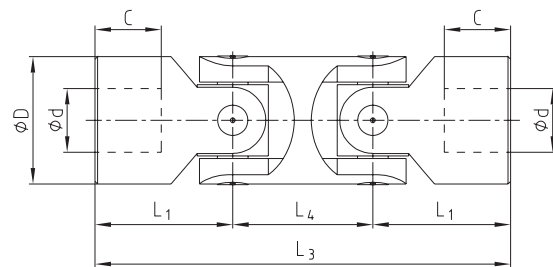

Finish bores:

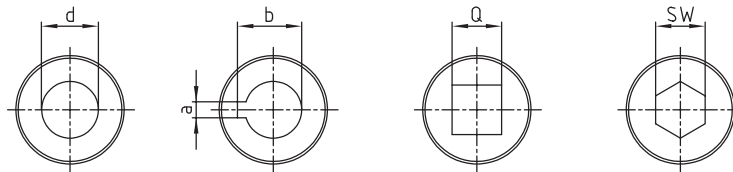

Type G and GD

Types and size		Type G and GD													Weight [kg]	
Size G	DIN description G	Size GD	DIN description GD	d [H7]	D	L ₂	L ₁	C	L ₄	L ₃	a [JS9]	b	Q [H8]	SW [H8]	G	GD
01 G	E6 x 16-G	01 GD	D6 x 16-G	6	16	34	17	8	22	56	2	7,0	6	6	0,05	0,08
02 G	E8 x 16-G	02 GD	D8 x 16-G	8	16	40	20	11	22	62	2	9,0	8	8	0,05	0,08
03 G	E10 x 22-G	03 GD	D10 x 22-G	10	22	48	24	12	26	74	3	11,4	10	10	0,10	0,15
04 G	E12 x 25-G	04 GD	D12 x 25-G	12	25	56	28	13	30	86	4	13,8	12	12	0,16	0,25
05 G	E14 x 28-G	05 GD	D14 x 28-G	14	28	60	30	14	36	96	5	16,3	14	14	0,20	0,40
1 G	E16 x 32-G	1 GD	D16 x 32-G	16	32	68	34	16	36	104	5	18,3	16	16	0,30	0,45
2 G	E18 x 36-G	2 GD	D18 x 36-G	18	36	74	37	17	40	114	6	20,8	18	18	0,45	0,70
3 G	E20 x 42-G	3 GD	D20 x 42-G	20	42	82	41	18	46	128	6	22,8	20	20	0,60	1,00
4 G	E22 x 45-G	4 GD	D22 x 45-G	22	45	95	47,5	22	50	145	6	24,8	22	22	0,95	1,55
5 G	E25 x 50-G	5 GD	D25 x 50-G	25	50	108	54	26	55	163	8	28,3	25	25	1,20	2,00
6 G	E30 x 58-G	6 GD	D30 x 58-G	30	58	122	61	29	68	190	8	33,3	30	30	1,85	2,90
6 G1	E32 x 58-G	6 GD1	D32 x 58-G	32	58	130	65	33	68	198	10	35,3	30	30	2,00	3,00
7 G	E35 x 70-G	7 GD	D35 x 70-G	35	70	140	70	35	72	212	10	38,3	-	-	3,15	4,75
8 G	E40 x 80-G	8 GD	D40 x 80-G	40	80	160	80	39	85	245	12	43,3	-	-	4,60	7,20
9 G	E50 x 95-G	9 GD	D50 x 95-G	50	95	190	95	46	100	290	14	53,8	-	-	7,60	12,0

Ordering example:

04 G	Ø12	Ø12 keyway DIN
Size/type of joint	Finish bore (H7)	Finish bore (H7) keyway to DIN 6885 sheet 1 (JS9)

Type H and HD according to DIN 808 with needle bearing



- Suitable for every application in the range of general engineering up to a maximum speed of 4000 rpm
- Type H precision single joint
- Type HD precision double joint
- Maximum articulation angle 45°
- High dynamic load - small bearing clearance
- Maintenance-free due to needle bearing
- Available with finish bore H7 – on request with keyway, hexagon bore or square bore
- Also available as clamping hub

Precision single joint H

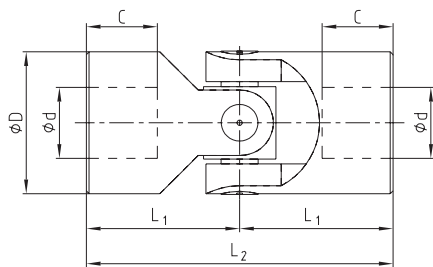

Precision double joint HD

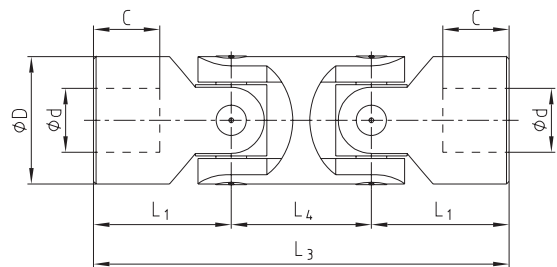

Finish bores:

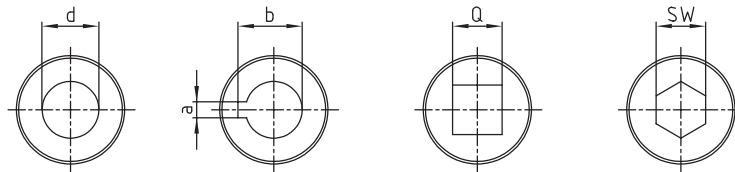

Type H and HD																
Types and size				Dimensions [mm]											Weight [kg]	
Size H	DIN description H	Size HD	DIN description HD	d [H7]	D	L ₂	L ₁	C	L ₄	L ₃	a [JS9]	b	Q [H8]	SW [H8]	H	HD
03 H	E10 x 22-W	03 HD	D10 x 22-W	10	22	48	24	12	26	74	3	11,4	10	10	0,10	0,15
04 H	E12 x 25-W	04 HD	D12 x 25-W	12	25	56	28	13	30	86	4	13,8	12	12	0,16	0,25
05 H	E14 x 28-W	05 HD	D14 x 28-W	14	28	60	30	14	36	96	5	16,3	14	14	0,20	0,40
1 H	E16 x 32-W	1 HD	D16 x 32-W	16	32	68	34	16	36	104	5	18,3	16	16	0,30	0,45
2 H	E18 x 36-W	2 HD	D18 x 36-W	18	36	74	37	17	40	114	6	20,8	18	18	0,45	0,70
3 H	E20 x 42-W	3 HD	D20 x 42-W	20	42	82	41	18	46	128	6	22,8	20	20	0,60	1,00
4 H	E22 x 45-W	4 HD	D22 x 45-W	22	45	95	47,5	22	50	145	6	24,8	22	22	0,95	1,55
5 H	E25 x 50-W	5 HD	D25 x 50-W	25	50	108	54	26	55	163	8	28,3	25	25	1,20	2,00
6 H	E30 x 58-W	6 HD	D30 x 58-W	30	58	122	61	29	68	190	8	33,3	30	30	1,85	2,90
6 H1	E32 x 58-W	6 HD1	D32 x 58-W	32	58	130	65	33	68	198	10	35,3	30	30	2,00	3,00
7 H	E35 x 70-W	7 HD	D35 x 70-W	35	70	140	70	35	72	212	10	38,3	-	-	3,15	4,75
8 H	E40 x 80-W	8 HD	D40 x 80-W	40	80	160	80	39	85	245	12	43,3	-	-	4,60	7,20
9 H	E50 x 95-W	9 HD	D50 x 95-W	50	95	190	95	46	100	290	14	53,8	-	-	7,60	12,0

Ordering example:	1 H	Ø16	Ø16 keyway DIN
	Size/type of joint	Finish bore (H7)	Finish bore (H7) keyway to DIN 6885 sheet 1 (JS9)

Type GA and HA acc. to DIN 808 with plain and needle bearing (extendable)



- Precision double joint - extendable, maximum articulation angle 45° for each joint
- Bridging larger shaft distances
- Type GA (plain bearing) $n_{max.} = 1000$ rpm
- Type HA (needle bearing) $n_{max.} = 4000$ rpm
- Available with quick locking GR; HR
- Available with finish bore H7 – on request available with key-way, thread for setscrews, square or hexagon bore
- Also available as clamping hub

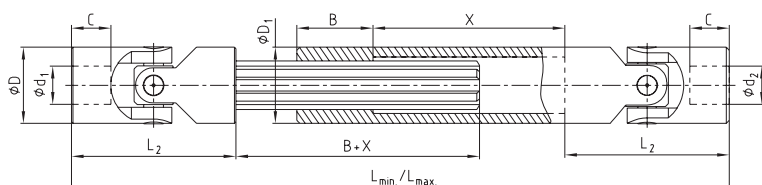

Finish bores:

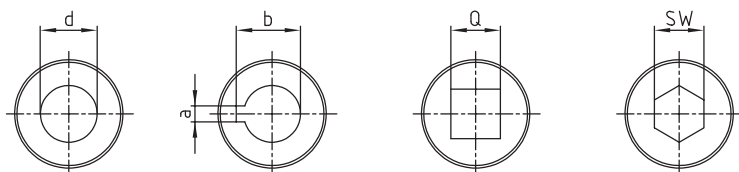

Preferred lengths									
Size	Dimensions [mm]								
	L _{min.} / L _{max.}								
03	140	160	180	230					
	170	200	240	330					
04	160	180	200	220	250	280	300		
	190	225	270	300	355	420	450		
05	170	180	200	220	250	280	300	350	400
	200	220	260	300	350	420	450	550	650
1	190	210	240	250	275	300	380	400	
	220	250	320	350	390	430	590	630	
2	230	250	270	290	300	400	500		
	280	320	370	400	415	620	820		
3	250	270	290	320	380	420	500		
	300	340	380	440	560	640	800		
4	250	270	290	330	350	470			
	280	320	350	430	470	710			
5	295	310	350	380	420	460	500		
	345	375	450	500	590	660	745		
6	330	350	370	400	450	500	540		
	380	420	455	510	620	720	795		

Type GA with plain bearing $n_{max.} = 1000$ rpm and type HA with needle bearing $n_{max.} = 4000$ rpm														
Size		Dimensions [mm]											Splines shaft	D ₁
GA	HA	d ₁ , d ₂ [H7]	D	L ₂	C	L _{min.} / L _{max.} / X		B	a [JS9]	b	Q [H8]	SW [H8]		
01 GA	-	6	16	34	8	←	→	25	2	7,0	6	6	SW8	16
02 GA	-	8	16	40	11	←	→	25	2	9,0	8	8	SW8	16
03 GA	03 HA	10	22	48	12	←	→	30	3	11,4	10	10	11 x 14 Z6	22
04 GA	04 HA	12	25	56	13	←	→	40	4	13,8	12	12	13 x 16 Z6	26
05 GA	05 HA	14	28	60	14	←	→	40	5	16,3	14	14	13 x 16 Z6	29
1 GA	1 HA	16	32	68	16	←	→	40	5	18,3	16	16	16 x 20 Z6	32
2 GA	2 HA	18	36	74	17	←	→	40	6	20,8	18	18	18 x 22 Z6	37
3 GA	3 HA	20	42	82	18	←	→	45	6	22,8	20	20	21 x 25 Z6	42
4 GA	4 HA	22	45	95	22	←	→	50	6	24,8	22	22	23 x 28 Z6	47
5 GA	5 HA	25	50	108	26	←	→	50	8	28,3	25	25	26 x 32 Z6	52
6 GA	6 HA	30	58	122	29	←	→	60	8	33,3	30	30	32 x 38 Z8	58
7 GA	7 HA	35	70	140	35	←	→	70	10	38,3	-	-	36 x 42 Z8	70
8 GA	8 HA	40	80	160	39	←	→	80	12	43,3	-	-	42 x 48 Z8	80
9 GA	9 HA	50	95	190	46	←	→	90	14	53,8	-	-	46 x 54 Z8	95

Calculation of mounting lengths L and X (stroke)

$$\text{Stroke } X \geq (L_{max} - 2 \cdot L_2 - B) / 2$$

$$L_{min.} \geq (L_{max} + 2 \cdot L_2 + B) / 2$$

$$\text{Minimum dimension } L_{min.} = L_2 + B + X + L_2$$

Ordering example:	3 GA	d ₁ = Ø20	d ₂ = Ø20 keyway DIN	550/650
	Size/type of joint	Finish bore (H7)	Finish bore (H7), keyway to DIN 6885 sheet 1 (JS9)	Mounting length L _{min.} /L _{max.}

Type X and XD acc. to DIN 808 with plain bearing (stainless steel 1.4301)



- Suitable for every application in the range of general engineering up to a maximum speed of 300 rpm
- Type X precision single joint
- Type XD precision double joint
- Maximum articulation angle 45° for each joint
- Available with finish bore H7 – on request with keyway, hexagon bore or square bore

Precision single joint X

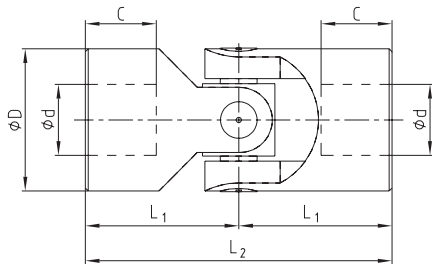

Precision double joint XD

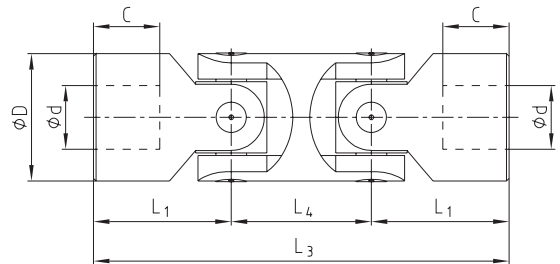

Finish bores:

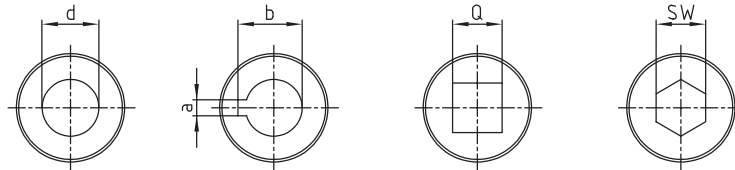

Type X and XD																
Type and size				Dimensions [mm]											Weight [kg]	
Size X	DIN description X	Size XD	DIN description XD	d [H7]	D	L ₂	L ₁	C	L ₄	L ₃	a [JS9]	b	Q [H8]	SW [H8]	X	XD
01 X	E6 x 16-G	01 XD	D6 x 16-G	6	16	34	17	8	22	56	2	7,0	6	6	0,05	0,08
02 X	E8 x 16-G	02 XD	D8 x 16-G	8	16	40	20	11	22	62	2	9,0	8	8	0,05	0,08
03 X	E10 x 22-G	03 XD	D10 x 22-G	10	22	48	24	12	26	74	3	11,4	10	10	0,10	0,15
04 X	E12 x 25-G	04 XD	D12 x 25-G	12	25	56	28	13	30	86	4	13,8	12	12	0,16	0,25
1 X	E16 x 32-G	1 XD	D16 x 32-G	16	32	68	34	16	36	104	5	18,3	16	16	0,30	0,45
3 X	E20 x 42-G	3 XD	D20 x 42-G	20	42	82	41	18	46	128	6	22,8	20	20	0,60	1,00
5 X	E25 x 50-G	5 XD	D25 x 50-G	25	50	108	54	26	55	163	8	28,3	25	25	1,20	2,00
6 X	E30 x 58-G	6 XD	D30 x 58-G	30	58	122	61	29	68	190	8	33,3	30	30	1,85	2,90

Ordering example:	04 X	Ø12	Ø12 keyway DIN
	Size/type of joint	Finish bore (H7)	Finish bore (H7) keyway to DIN 6885 sheet 1 (JS9)

Type GR and HR with quick locking

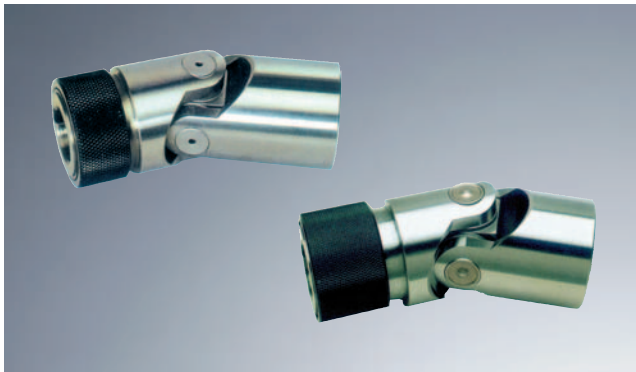

- Precision single joint with quick locking (separable)
- Type GR with plain bearing $n_{max.} = 1000$ rpm
- Type HR with needle bearing $n_{max.} = 4000$ rpm
- Maximum articulation angle 45°
- Quick locking (d_2) available with H7 bore and keyway to DIN 6885 sheet 1 – JS9 or hexagon bore

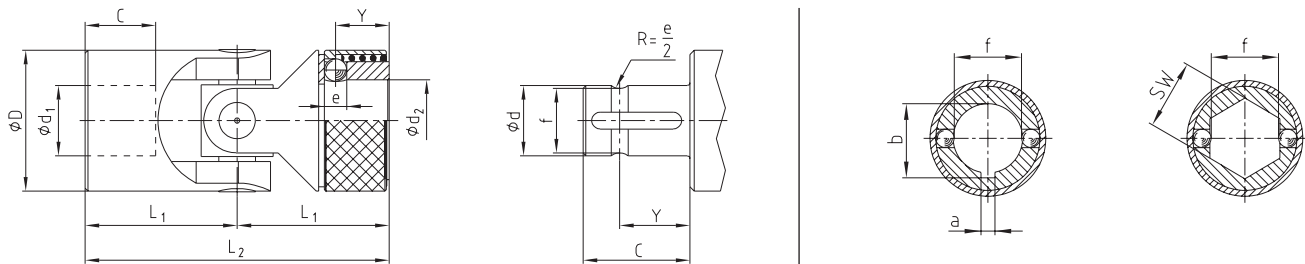

Type GR with plain bearing $n_{max.} = 1000$ rpm and type HR with needle bearing $n_{max.} = 4000$ rpm												
Size		Dimensions [mm]										
GR	HR	d_1, d_2 [H7]	D	L_2	L_1	C	Y	e	f	a [JS9]	b	SW [H8]
02 GR	-	8	16	52	26	14	9,5	3,5	7,0	2	9,0	8
03 GR	03 HR	10	22	62	31	17	11,5	4,0	8,7	3	11,0	10
04 GR	04 HR	12	25	74	37	21	13,5	4,0	11,0	4	13,3	12
05 GR	05 HR	14	25	74	37	21	13,5	4,0	13,0	5	15,3	14
1 GR	1 HR	16	32	86	43	24	14,0	6,35	14,8	5	17,3	16
2 GR	2 HR	18	36	96	48	28	19,0	8,0	16,0	6	19,8	18
3 GR	3 HR	20	42	108	54	31	19,0	8,0	18,0	6	22,3	20
4 GR	4 HR	22	45	120	60	34	20,5	10,0	20,0	6	24,8	22
5 GR	5 HR	25	50	132	66	38	20,5	10,0	23,0	8	28,3	25
6 GR	6 HR	30	58	166	83	49	25,0	10,0	28,0	8	33,3	30

Protection bush for joints type G, H, GA, HA and jX

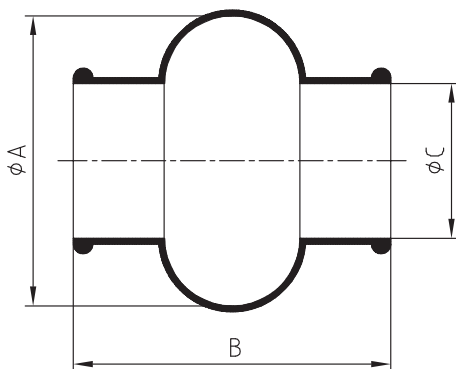

Protection bush				
Size	Precision joints	A	B	C
M 01	01 G, 01 X	28	34	15
M 02	02 G, 02 X	32	40	16,5
M 03	03 G, 03 H, 03 GA, 03 HA, 03 X	40	45	20,5
M 04	04 G, 04 H, 04 GA, 04 HA, 04 X	48	50	24,5
M 05	05 G, 05 H, 05 GA, 05 HA	52	56	27,5
M 1	1 G, 1 H, 1 GA, 1 HA, 1 X	56	65	30,5
M 2	2 G, 2 H, 2 GA, 2 HA	66	72	35,5
M 3	3 G, 3 H, 3 GA, 3 HA, 3 X	75	82	40,0
M 4	4 G, 4 H, 4 GA, 4 HA	84	95	45,0
M 5	5 G, 5 H, 5 GA, 5 HA, 5 X	92	108	50,0
M 6	6 G, 6 G1, 6 H, 6 H1, 6 GA, 6 HA, 6 X	100	122	56,0

Ordering example:	03 HR	$d_1 = \varnothing 10$	$d_2 = \varnothing 10$ keyway DIN
	Size/type of joint	Finish bore (H7)	Finish bore (H7) keyway to DIN 6885 sheet 1 (JS9)

Selection and determination of size acc. to DIN 808 with plain/needle bearing

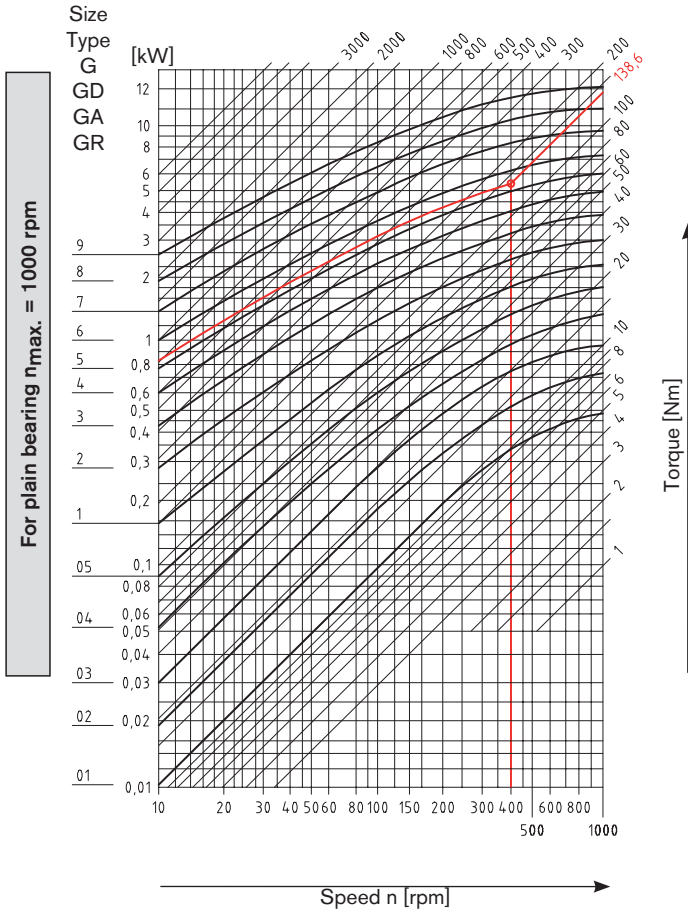

Selection of precision joints¹⁾ type G, GD, GA, GR (max. 1000 rpm)

45°	4,0
40°	3,3
35°	2,6
30°	2,2
25°	1,8
20°	1,5
15°	1,25
10°	1,00
5°	0,8
Articulation angle [α]	Correction value

The selection of the precision joints with plain bearing is based on the driving torque, taking into account a correction value which depends on the articulation angle α and the operating speed. For the extendable joints in addition the overall length and the speed have to be considered to determine the size (please consult with KTR engineering department).

Torque \cdot correction value = selected torque M_t

Example of selection

Driving torque M_t [Nm]	Correction value for articulation angle [α]	Selected torque; Selection of size acc. to table
63	30°	
63	2,2	63 Nm \cdot 2,2 = 138,6 Nm

Operating speed = 400 rpm

The selection of the size according to the table is based on the driving torque (63 Nm) \cdot correction value (30° = 2,2) = 138,6 Nm and the operating speed of 400 rpm. Selected: Joint size 6

Torque [Nm] = 9550 \cdot Power [kW] / speed [rpm]

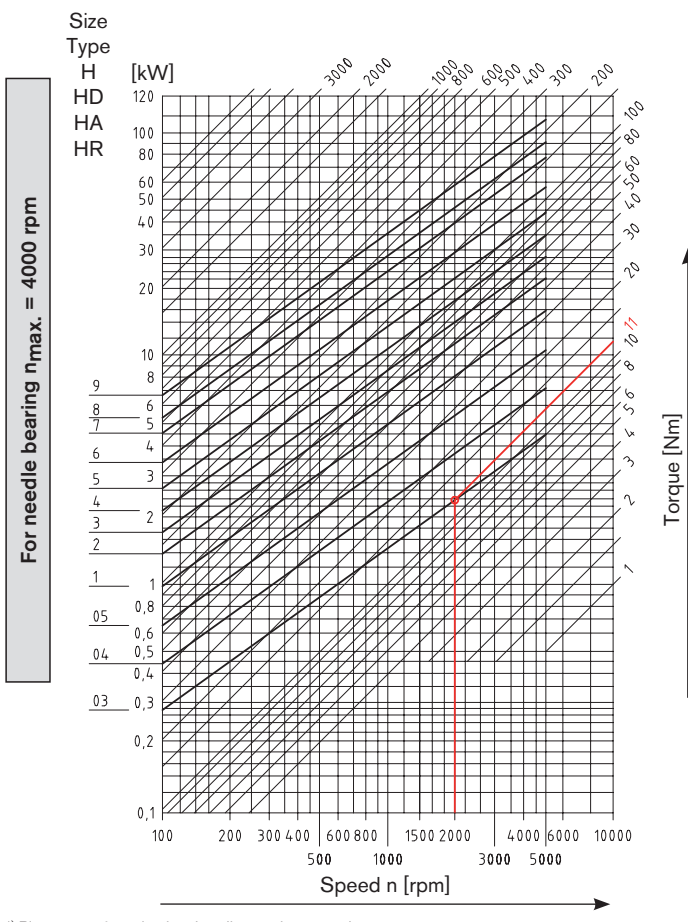

Selection of precision joints¹⁾ type H, HD, HA, HR (max. 4000 rpm)

45°	4,0
40°	3,3
35°	2,5
30°	2,0
25°	1,4
20°	1,25
15°	1,1
10°	1,00
5°	0,8
Articulation angle [α]	Correction value

The selection of the precision joints with needle bearing is based on the driving torque, taking into account a correction value which depends on the articulation angle α and the operating speed. For the extendable joints in addition the overall length and the speed have to be considered to determine the size (please consult with KTR engineering department).

Torque \cdot correction value = selected torque M_t

Example of selection

Driving torque M_t [Nm]	Correction value for articulation angle [α]	Selected torque; Selection of size acc. to table
8,8	20°	
8,8	1,25	8,8 Nm \cdot 1,25 = 11 Nm

Operating speed = 2000 rpm

The selection of the size according to the table is based on the driving torque (8,8 Nm) \cdot correction value (20° = 1,25) = 11 Nm and the operating speed of 2000 rpm. Selected: Joint size 03

Torque [Nm] = 9550 \cdot Power [kW] / speed [rpm]

¹⁾ Please note for selection: bending angle \cdot speed \leq 40000