



DATAFLEX®

Torque measuring shaft type 85/...



DATAFLEX® is a maintenance-free torque measuring shaft with integrated speed measurement. Combined with the steel lamina coupling **RADEX®-N** the complete system forms a torsionally stiff, double-cardanic coupling with integrated measuring shaft.

Table of contents

- 1 Technical data**
- 2 Advice**
 - 2.1 General advice
 - 2.2 Safety and advice symbols
 - 2.3 General hazard warnings
 - 2.4 Intended use
- 3 Storage**
- 4 Assembly**
 - 4.1 Components of DATAFLEX® torque measuring shaft
 - 4.2 Advice regarding finish bore
 - 4.3 Displacements - alignment of the torque measuring shaft
 - 4.4 Assembly of the hubs
 - 4.5 Assembly of the RADEX®-N clamping ring hubs on the DATAFLEX® torque measuring shaft
 - 4.6 Assembly of the hubs on driving and driven side
 - 4.7 Assembly of the lamina sets
 - 4.8 Tightening torque of the fitting screws
 - 4.9 Advice for assembly of the DATAFLEX® torque measuring shaft
 - 4.10 Technical description
 - 4.11 Services, customer service addresses
- 5 EC certificate of conformity**



1 Technical data

DATAFLEX® torque measuring shaft

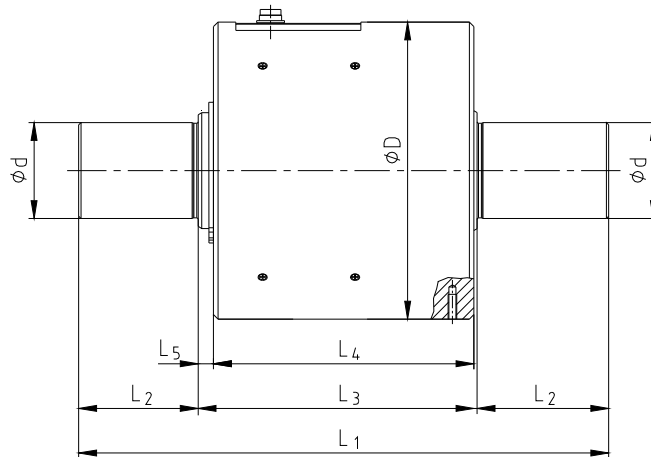

Illustration 1: DATAFLEX® torque measuring shaft

Table 1: Dimensions

DATAFLEX® type	Dimensions [mm]						
	d	D	L ₁	L ₂	L ₃	L ₄	L ₅
85/2000	85	215	344	90	164	153	10
85/5000							
85/10000							

Table 2: Technical data

Coupling size DATAFLEX®	85/2000	85/5000	85/10000
Electrical data			
Nominal torque T _{KN} [Nm]	-2000 .. +2000 Nm	-5000 .. +5000 Nm	-10000 .. +10000 Nm
Band width of torque signal [kHz] (-3dB)	16		
Error in linearity incl. hysteresis [%] ¹⁾	< ±0,5		
Influence of temperature [%/10K]	0,5		
Nominal temperature range [°C]	0 - 55		
Supply voltage [V] DC	24 ± 4		
Max. current consumption [mA]	100		
Torque output			
Output voltage torque [V]	0 ... 10		
Output current torque [mA]	4 ... 20		
Speed output ²⁾			
Number of impulses / revolution	60		
Amplitude [V]	24/5V		
DC speed output [V]	0 - 10		
Scale of direct voltage output	16 settings via micro switch		
Inaccuracy of DC output [%] ³⁾	± 0,2		
Direction signal [V]	to be omitted		
Mechanical data			
Static load limit T _{Kmax.} ¹⁾ [%]	150		
Breaking load T _{K break} ¹⁾ [%]	300		
Max. bending torque [Nm]	380	760	1270
Max. radial force [N]	1500	3000	5000
Max. axial force [kN]	50	80	110
Weight [kg]	22,6	23,3	23,9
Torsion spring stiffness C _T [Nm/rad]	382000	818570	1273330
Torsion angle with T _{KN} [degrees]	0,30	0,35	0,45
Mass moment of inertia [kgmm ²]	16360	16790	17420
Max. speed [rpm]	2500		

- 1) Referring to rated torque T_{KN}
- 2) With connection housing DF2
- 3) Referring to measuring range value

Please note protection mark ISO 16016.	Drawn:	03.09.13 Pz/Koe	Replaced for:	KTR-N valid from 28.05.13
	Verified:	22.10.13 Pz	Replaced by:	



1 Technical data

DATAFLEX® torque measuring shaft in combination with RADEX®-N

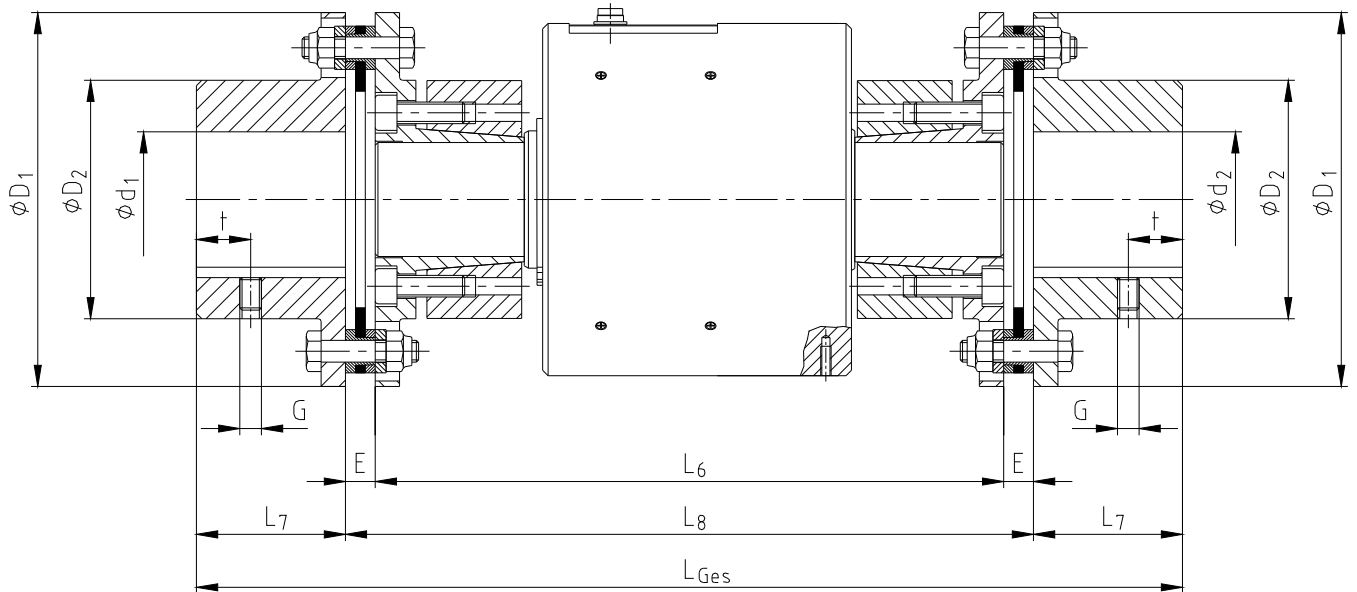

Illustration 2: DATAFLEX® with RADEX®-N

Table 3: Dimensions and technical data

Coupling size DATAFLEX®	85/2000	85/5000	85/10000
Coupling size RADEX®-N	105	115	135
Dimensions [mm]			
Dimension d ₁ /d ₂ max.	105	115	135
Dimension D ₁	225	265	305
Dimension D ₂	147	163	184
Dimension L ₆	344	364	434
Dimension L ₇	90	100	135
Dimension L ₈	384	410	488
Dimension L _{Ges}	564	610	758
Dimension E	20	23	27
Setscrew [mm]			
Dimension G	M12	M12	M20
Dimension t	30	30	40
Tightening torque T _A [Nm]	40	40	140
Mechanical data of the combination (DATAFLEX® with RADEX®-N)			
Mass moment of inertia [kgmm ²]	225000	473500	1006700
Torsion spring stiffness [Nm/rad]	29300	55600	92800
Weight [kg]	61,5	85,6	130,2
Max. speed [rpm] ¹⁾		2500	

1) Higher speeds on request.



2 Advice

2.1 General advice

Please read through these assembly/operating instructions carefully before you start up the measuring shaft. Please pay special attention to the safety instructions! The mounting instructions are part of your product. Please keep them carefully and close to the measuring shaft. The copyright for these mounting instructions remains with KTR Kupplungstechnik GmbH.

2.2 Safety and advice symbols



DANGER!

Danger of injury to persons.



CAUTION!

Damages on the machine possible.



ATTENTION!

Pointing to important items.

2.3 General hazard warnings



DANGER!

With the assembly, operation and maintenance of the measuring shaft it is important to secure the entire drive train against accidental switch-on. Please read through and observe the following safety instructions.

- All operations with and on the measuring shaft must be performed based on the idea of "Safety First".
- Secure the measuring shaft and the disengaged drive before the operations are performed.
- Secure the drive system against accidental switch-on, for example place warning signs at the switch or remove the fuse.
- Do not touch the measuring shaft when it is in operation.
- Protect the measuring shaft from accidental contact. Use an appropriate cover or shield.

2.4 Intended use

You may only assemble, operate and maintain the measuring shaft if you

- carefully read through the mounting instructions and understood them
- had technical training
- are authorized by your company

The measuring shaft can only be used in accordance with the technical data (see table 1 to 3). Unauthorized alterations to the measuring shaft are not allowed. We will not assume liability for any damage that may arise. In the interest of further development we reserve the right for technical modifications.

The **DATAFLEX® torque measuring shaft** described corresponds to the technical status at the time of printing these assembly instructions.

Please note protection mark ISO 16016.	Drawn: 03.09.13 Pz/Koe	Replaced for: KTR-N valid from 28.05.13
	Verified: 22.10.13 Pz	Replaced by:



3 Storage

The **RADEX®-N** couplings are supplied in preserved condition. Both **DATAFLEX®** and **RADEX®-N** can be stored at a dry and covered place for 6 - 9 months.



CAUTION!

Humid storage rooms are not suitable.

Please make sure that condensation is not generated. The best relative air humidity is less than 65%.

4 Assembly

The measuring shaft and the couplings are supplied as single pre-assembled structural components. Before assembly the measuring shaft should be checked for completeness. The position of the **DATAFLEX®** is variable. The measurement system can be mounted horizontally as well as vertically.

4.1 Components of DATAFLEX® torque measuring shaft

Components of
DATAFLEX® torque measuring shaft

Component	Quantity	Designation
1	1	DATAFLEX® torque measuring shaft

Components of RADEX®-N coupling

Component	Quantity	Designation
2	2	Flange hub
3	2	Lamina set
4	2	Clamping ring hub with clamping ring
5	2	Setscrew DIN EN ISO 4029

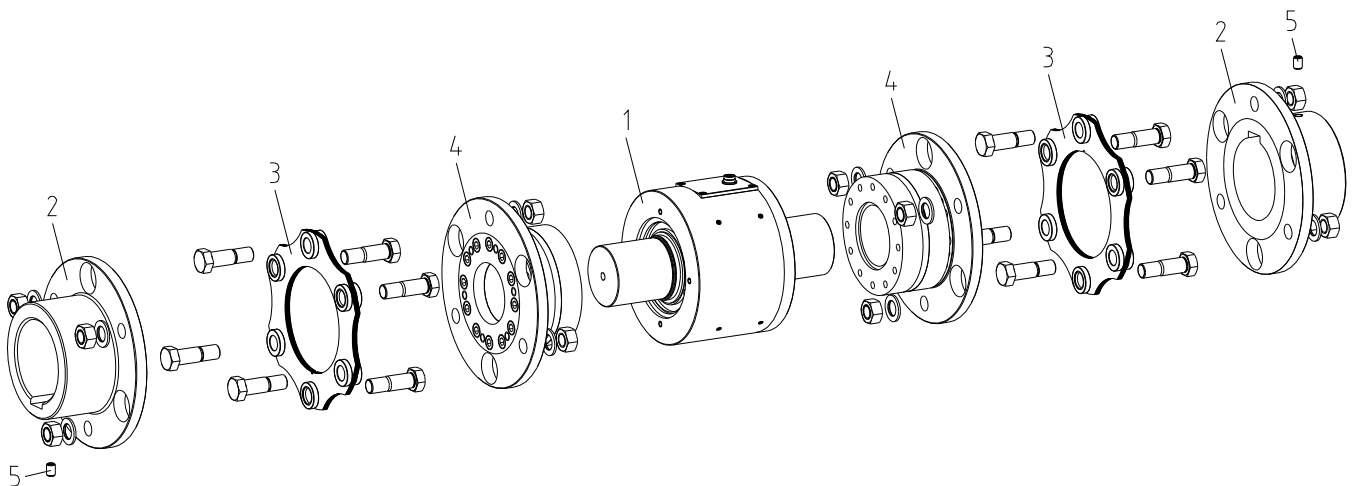

Illustration 3: DATAFLEX® 85 - torque measuring shaft with RADEX®-N



4 Assembly

4.2 Advice regarding finish bore



DANGER!

The maximum permissible bore diameters d_{1max} and d_{2max} (see RADEX®-N catalogue) must not be exceeded. If these figures are disregarded, the coupling may tear. Rotating particles may cause danger to life.

- Hub bores machined by the customer have to observe concentricity or axial runout, respectively (see illustration 4).
- Please make absolutely sure to observe the figures for $\varnothing d_{1max}$ and $\varnothing d_{2max}$.
- Carefully align the hubs when the finish bores are drilled.
- Please provide for a setscrew according to DIN EN ISO 4029 with cup point or an end plate for the axial fastening of the hubs.

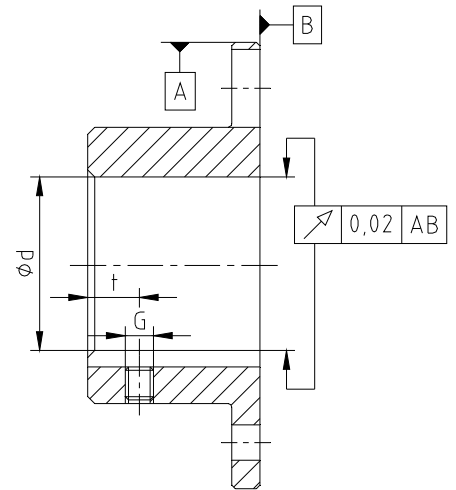

Illustration 4: concentricity and axial run-out

4.3 Displacements - alignment of the torque measuring shaft

The displacement figures shown in table 4 provide for sufficient safety to compensate for external influences like, for example, heat expansion or foundation settling.



CAUTION!

In order to ensure a long service life of the measuring shaft the shaft ends must be accurately aligned. Please absolutely observe the displacement figures indicated (see table 4). If the figures are exceeded, the measuring shaft with coupling will be damaged.

Please note:

- The displacement figures given in table 4 are maximum values. They cannot occur at the same time. When radial, axial and angular displacement occurs simultaneously, these values must be reduced (see illustration 6).
- Please inspect with a dial gauge, ruler or feeler whether the permissible displacement figures of table 4 can be observed.

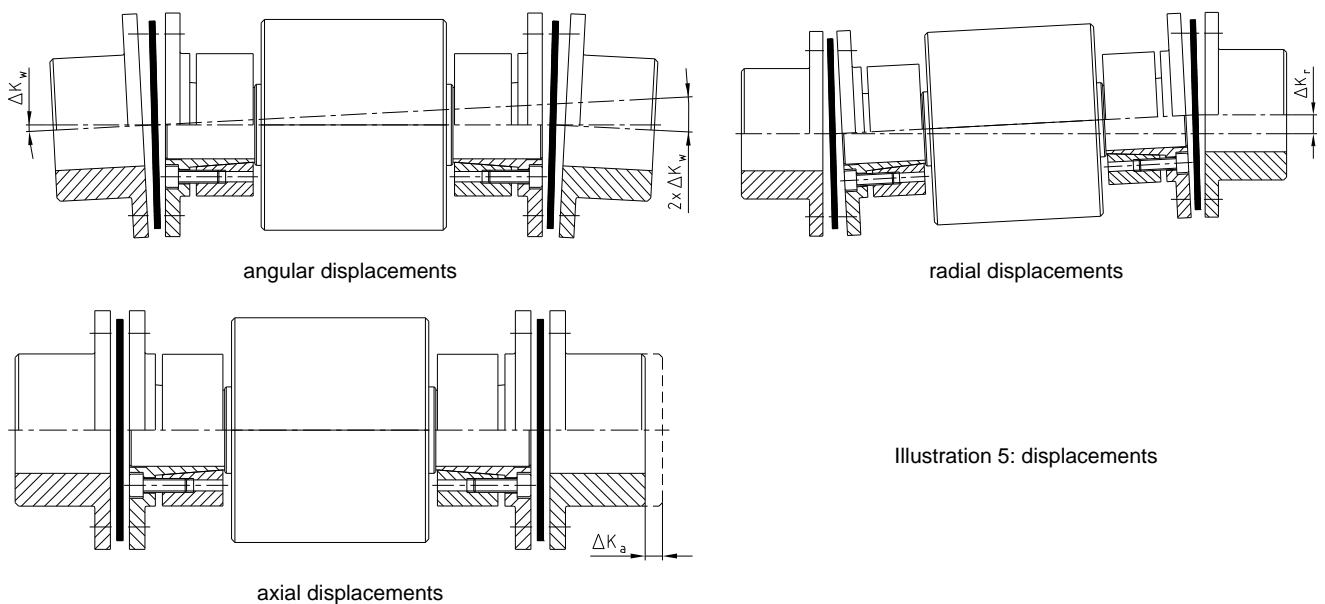

Illustration 5: displacements

Please note protection mark ISO 16016.	Drawn: 03.09.13 Pz/Koe	Replaced for: KTR-N valid from 28.05.13
	Verified: 22.10.13 Pz	Replaced by:



4 Assembly

4.3 Displacements - alignment of the torque measuring shaft

Table 4: Displacement figures

DATAFLEX® size	RADEX®-N size	Max. axial displacement ΔK_a [mm]	Max. radial displacement ΔK_r [mm]	Max. angular displacement ΔK_w [degree]
85/2000	105	2,4	6,3	1,0 (each lamina package)
85/5000	115	2,8	6,7	
85/10000	135	3,5	8,0	

Illustration 6: combination of displacements

Examples for the displacement combinations given in illustration 6:

Example:

$\Delta K_r = 60\%$
 $\Delta K_w = 20\%$
 $\Delta K_a = 20\%$

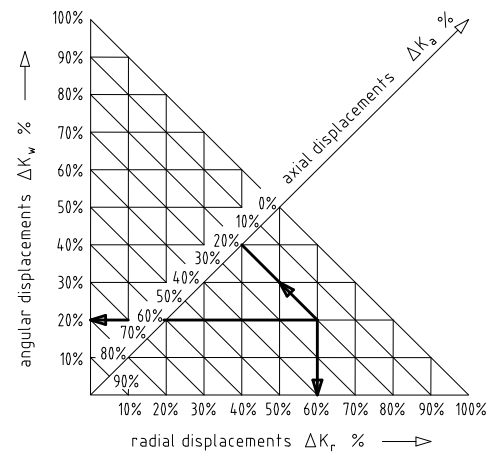

$$\Delta K_{\text{total}} = \Delta K_a + \Delta K_r + \Delta K_w \leq 100\%$$

4.4 Assembly of the hubs



ATTENTION!

We recommend to inspect bores, shaft, keyway and feather key for dimensional accuracy before assembly.

4.5 Assembly of the RADEX®-N clamping ring hubs on the DATAFLEX® torque measuring shaft

The force is transmitted through a frictional connection. The fit for the shaft and clamping ring hub is H7/h6.

During assembly please pay attention to the following procedures:

- Please clean and degrease the contact surfaces of the hub bores and the shafts before assembly.



CAUTION!

Oil and grease with Molybdenum Disulfide or other hydrocarbons as well as grease paste should not be used.

- The clamping screws must be lightly unscrewed, the clamping ring hub should be placed on the shaft and adjusted to the L_6 dimension (see illustration 7 and 8).
- The clamping screws must be tightened evenly crosswise. The tightening torques should be increased gradually. This procedure should be repeated until the tightening torque of all of the clamping screws corresponds to the value given in table 5.



4 Assembly

4.5 Assembly of the RADEX®-N clamping ring hubs on the DATAFLEX® torque measuring shaft

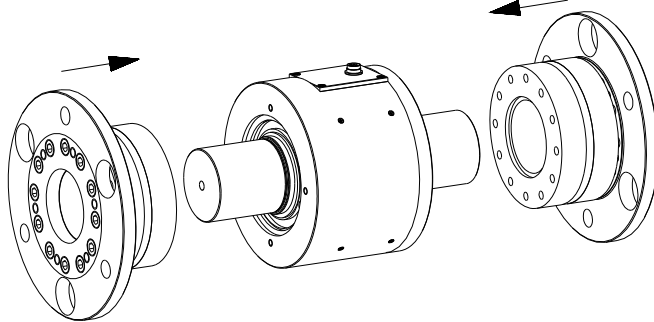

Illustration 7: assembly of the clamping ring hubs

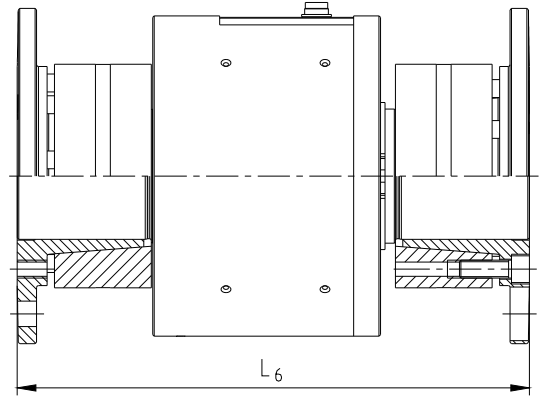

Illustration 8: adjusting to the L_6 dimension

Table 5: Tightening torque of the clamping screws

Coupling size DATAFLEX®	85/2000	85/5000	85/10000
Coupling size RADEX®-N	105	115	135
Screw size	M12	M12	M16
Number z	9	12	9
Tightening torque T_A [Nm]	120	120	295
Transmittable torque [Nm] ¹⁾ (frictional torque)	8000	10900	15600

1) H7/h6 shaft/hub fit

4.6 Assembly of the hubs on driving and driven side

- Assemble the hubs on the shafts of the driven and driving side (illustration 9). The ends of the shafts must not protrude through the hubs.
- Move the units in axial direction until the dimension L_8 is achieved (illustration 10).
- If the unit is fixed move the hubs on the shaft to achieve the L_8 dimension.



ATTENTION!

On request the hubs can be machined for a set screw to secure the hubs in axial direction. Please mention this request in your order.



CAUTION!

During assembly please make sure the correct L_8 is observed (table 3). If this is not done the measuring shaft (coupling) can be damaged.

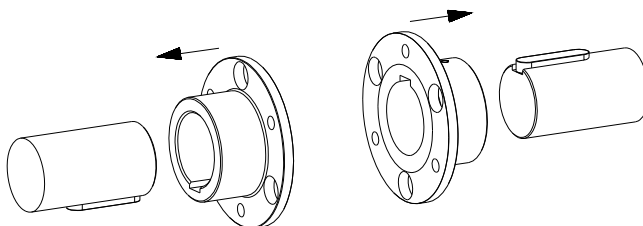

Illustration 9: assembly of the driven and driving side hubs

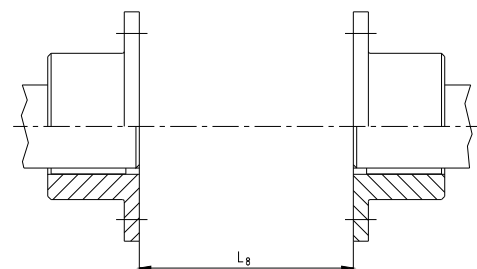

Illustration 10: adjusting to the L_8 dimension



4 Assembly

4.7 Assembly of the lamina sets



CAUTION!

During assembly it is important that the lamina sets are assembled free from distortion in axial direction. If this is not done the coupling can be damaged.

- Insert the lamina sets and the DATAFLEX® measuring shaft.
- Screw the components hand-tight for the time being, while the fitting screws have to be mounted offset from left to right (see illustration 11).
- Tighten the fitting screws to the tightening torques mentioned in table 6 by means of a torque key.

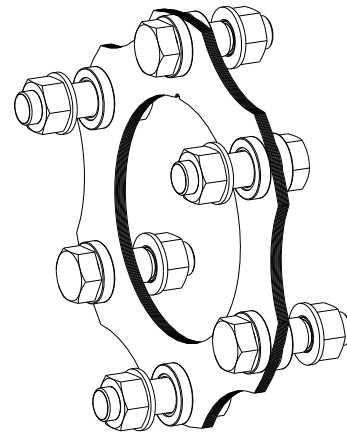
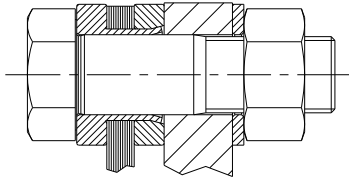

Illustration 11: assembly of the lamina sets

4.8 Tightening torque of the fitting screws

The fitting screws have to be tightened to the tightening torques T_A mentioned in table 6.

Table 6: Tightening torque of the fitting screws

Coupling size DATAFLEX®	85/2000	85/5000	85/10000
Coupling size RADEX®-N	105	115	135
Screw size	M16	M20	M24
Tightening torque T_A [Nm]	280	550	900



CAUTION!

After the coupling has been put into operation the tightening torque of the fitting screws should be checked during normal maintenance intervals.

4.9 Advice for assembly of the DATAFLEX® torque measuring shaft

- Fix the housing



CAUTION!

The housing must be protected from rotation. For this purpose there is a thread size M4 at the bottom side. Please make absolutely sure to avoid a rigid fixing of the housing!



CAUTION!

Opening the housing is not required and can lead to damage of the measurement shaft.



4 Assembly

4.9 Advice for assembly of the DATAFLEX® torque measuring shaft

- **Insulation**
All DATAFLEX® measuring shafts of type 85 correspond to the Protection IP50 according to DIN EN 60529.
- **Maintenance**
The DATAFLEX® measuring shaft is maintenance-free. Lubrication or cleaning is not necessary.
- **Calibration**
The unit is supplied with a calibration sheet. We recommend to inspect the calibration every six months.

4.10 Technical description

1. General description

The overall measuring electronics is installed in the fixed housing so that additional devices for signal processing are not necessary. The measuring shaft can be wired either by the terminal housing DF2 available as accessories or manually by a 12-pole coupling (type Binder series 432) (pin configuration see table 7). The measuring system has three measuring terminals which the analogous terminal figures for torque and speed can be measured on. Two digital terminals show the current operating condition, while two digital inputs can be used for calibration.



ATTENTION!

The measuring shaft should initially be switched on when all of the connections have been properly connected. After it has been switched on for the first time the measuring shaft will take around 5 minutes until this warm up phase is finished and the measurement device will have its standard accuracy.

2. Pin assignment of the measuring shaft

Table 7: Pin assignment of the type Binder series 423 connection

Connection	Pin	Characteristic
Input Voltage		
Supply voltage +	24V _{IN} M	24 V DC ± 4 V / 100 mA
Supply voltage -	GND L	
Torque Output		
Output voltage +	U _{OUT} F	0 ... 10 V (R _A = 1 kΩ)
Output voltage -	GND E	
Output current +	I _{OUT} G	4 ... 20 mA (R _A ≤ 500 Ω)
Output current -	I _{OUT-} L	
Speed Output		
Output speed +	DRZ H	24 V / 60 impulse/revolution
Output speed -	GND J	
LED-Output		
Program-LED	U _{LED1+} D	5 V / 5 mA prepared for LED
	U _{LED1-} C	
Fault signal	U _{LED2+} K	24 V / 5mA prepared for LED
	GND L	
Calibration Input		
Auto-Offset	T1 A	activ on connection with GND
Program	T2 B	(Pin L)

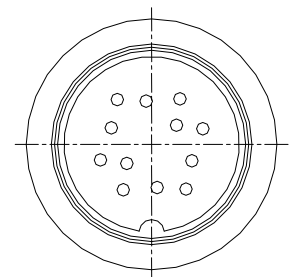

Illustration 12: plug connection
DATAFLEX®



4 Assembly

4.10 Technical description

3. Connection housing DF2

The connection housing DF2 has 12 screwed connections for power supply, display equipment and switches. The torque signal is displayed as proportional direct voltage 0 ... 10 V and as current of 4 ... 20 mA.

For speed output a square wave signal and a scalable voltage signal is available (for pin configuration see table 8).

The switch T1 serves for programming and can be bridged externally from GND via the terminal 12 (T1).

Table 8: Pin assignment of the connection housing DF2

No.	Designation	Function	Characteristic
Input voltage			
10	24V	Supply voltage +	24 V DC \pm 4 V / 100 mA
11	GND	Supply voltage -	
Torque output			
4	M-U	Output voltage +	0 V ... 10 V ($R_A = 1 \text{ k}\Omega$)
5	GND	Ground torque output	
6	M-I	Output current	4 mA ... 20 mA
Speed output pulse signal			
7	N1	Speed output channel 1	HTL (24V, 60 pulses /rev.) TTL (5V, 60 pulses /rev.)
8	GND	Ground for pulse speed output	
9	N2	Without function	
Speed output DC-voltage			
1	R/L	Without function	
2	GND	Ground for DC speed output	
3	N-U	Speed output DC-voltage	0 V ... 10 V (scalable)
Other connections / operating device			
12	T1	Push button T1	External connection T1
13	L1, L2	Signal LED's	
14	T1, T2	Push button T1, T2	Push button for programming
15	TP	Switch low pass filter	On/off switch low-pass
16	-	Connection measuring shaft	1:1 Connection Cable
17	-	Switch for speed scaling	see table 12

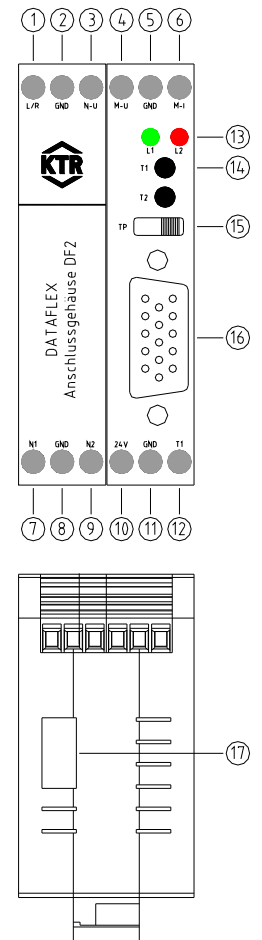

Illustration 13:
connection housing DF2

4. Description of connections

a) Supply voltage 24V

The supply voltage is 24V DC with a maximum current consumption of 100 mA.

b) Torque output U, I

To record the torque there are a voltage and a current output available. Both outputs can be used at the same time.



4 Assembly

4.10 Technical description

Table 9: Relation between torque - output values

DATAFLEX® size	$\Delta U / \Delta M$	$\Delta I / \Delta M$
85/2000	2,5 V / 1000 Nm	4 mA / 1000 Nm
85/5000	1 V / 1000 Nm	1,6 mA / 1000 Nm
85/10000	0,5 V / 1000 Nm	0,8 mA / 1000 Nm

The characteristic curves of the output are shown in illustration 14.1 and 14.2.

The characteristic curves of the output values (see illustration 14.1 and 14.2)

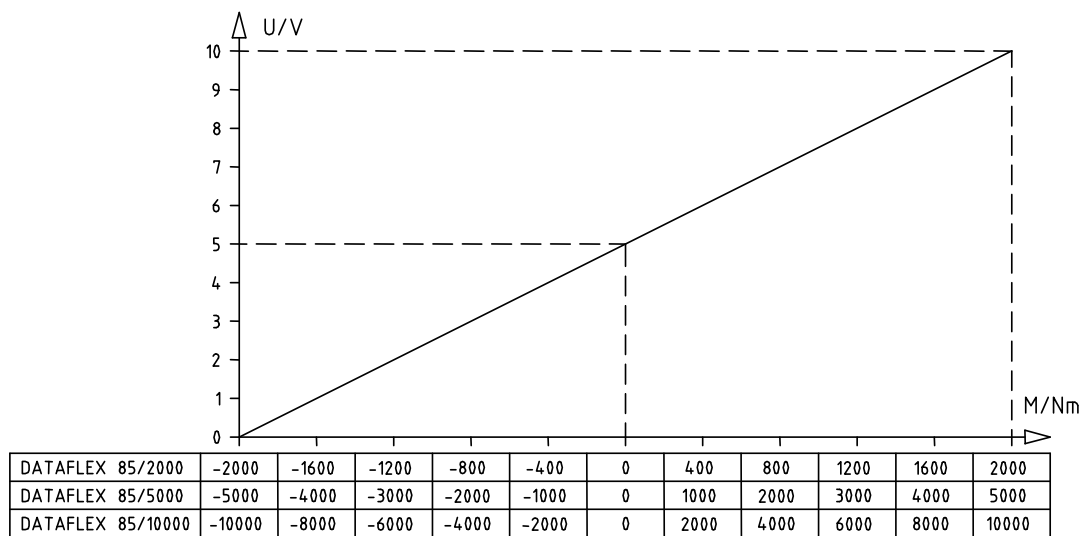

Illustration 14.1: voltage to torque relationship

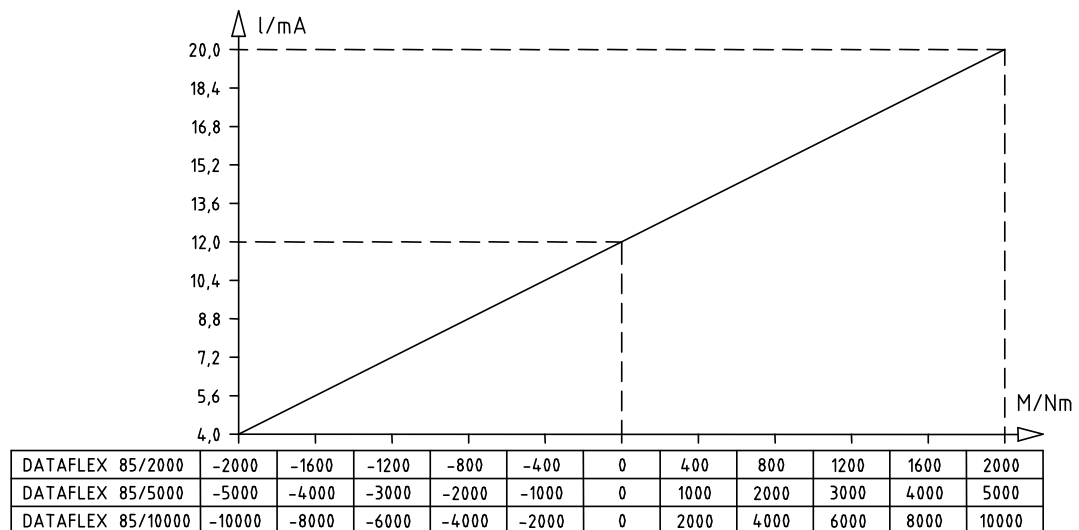

Illustration 14.2: current to torque relationship



4 Assembly

4.10 Technical description

- **Low pass filter (No. 15)**

If the connection housing DF2 is used, the signal of the voltage output can be filtered.

Table 10: Low pass switch (No. 15)

Button adjustment TP	Left	Right
	Low-Pass on	Low-Pass off

The limit frequency of the filter can be changed by varying the DIP switches (see illustration 15) inside the connection housing:

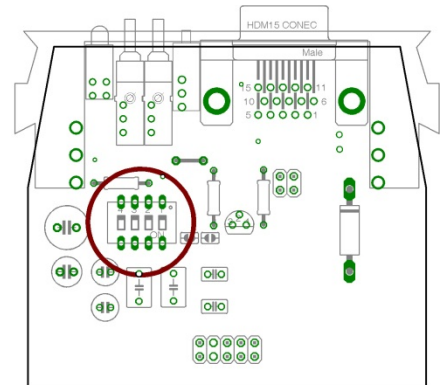

Illustration 15: position of DIP switch

Table 11: Adjustment of the requested filter frequency

Limit frequency [Hz]	Switch 1	Switch 2	Switch 3	Switch 4
15000	OFF	OFF	OFF	OFF
1000	OFF	OFF	OFF	ON
100	OFF	OFF	ON	OFF
10	OFF	ON	OFF	OFF
1	ON	OFF	OFF	OFF

A filter frequency of 1000 Hz is pre-set.

c) Output speed N1 (No. 7)

For determining the speed a square wave with a frequency of 60 pulses per revolution is available. The height of the square wave voltage is 24 volts.

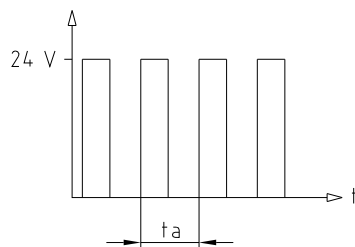

Illustration 16

$$\text{speed (1/min)} = 1 / t_a(\text{s})$$

$$\text{speed (1/min)} = f (1/\text{s})$$



4 Assembly

4.10 Technical description

Output circuit (connection N1)

The speed output N1 has short-circuit proof push-pull outputs providing a square-wave voltage with an amplitude of 24V and a maximum switching current of 30 mA. The output terminals must not be charged with an external voltage (see illustration 17).

The output voltage of speed lines can be varied by modifying the jumper position in the connection housing to 5V level (see illustration 18).

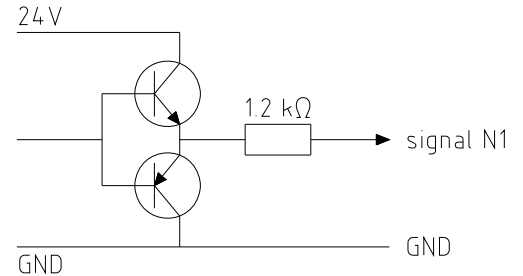
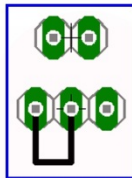

Illustration 17: output circuit of speed outputs

Outputs N1, N2, R/L = 24Vss:



Outputs N1, N2, R/L = 5Vss:

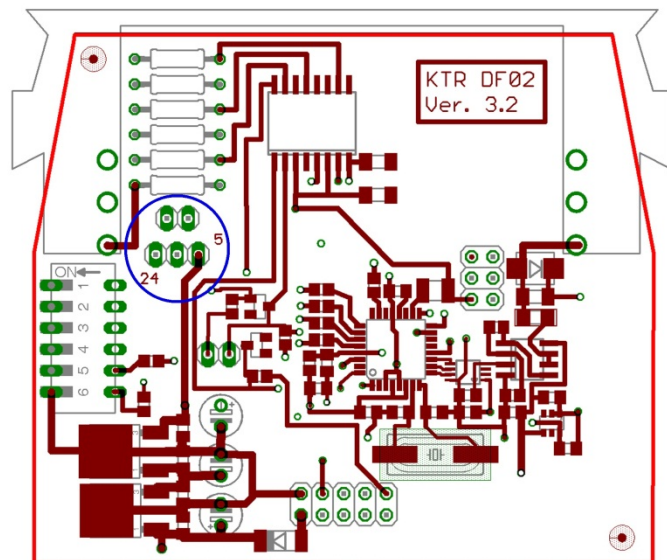
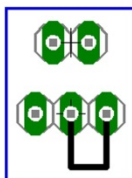

Illustration 18: modification of voltage level for the speed signal

d) Outputs N-U

The KTR connection housing DF02 contains an integrated f/U converter. It converts the pulses of the encoder to a linear DC-voltage output (terminal N-U).

On the bottom side of the connection housing DF02 there is a sixfold multiple switch allowing to adapt the scaling of the speed signal to the type of measuring shaft and the speed range (see illustration 13 and 19).

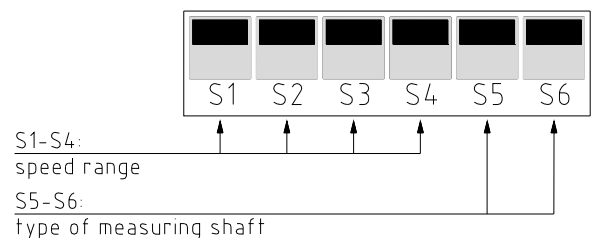

Illustration 19: switch positions

Please note protection mark ISO 16016.	Drawn: 03.09.13 Pz/Koe	Replaced for: KTR-N valid from 28.05.13
	Verified: 22.10.13 Pz	Replaced by:



4 Assembly

4.10 Technical description

Scaling of the speed direct voltage output

Table 12: Switch position S1-S4 and the corresponding scale of the speed output N-U

Max. speed	Scaling	S1	S2	S3	S4
10	1 U/min / V	0	0	0	0
20	2 U/min / V	0	0	0	1
40	4 U/min / V	0	0	1	0
60	6 U/min / V	0	0	1	1
80	8 U/min / V	0	1	0	0
100	10 U/min / V	0	1	0	1
200	20 U/min / V	0	1	1	0
400	40 U/min / V	0	1	1	1
600	60 U/min / V	1	0	0	0
800	80 U/min / V	1	0	0	1
1000	100 U/min / V	1	0	1	0
2000	200 U/min / V	1	0	1	1
4000	400 U/min / V	1	1	0	0
6000	600 U/min / V	1	1	0	1
8000	800 U/min / V	1	1	1	0
10000	1000 U/min / V	1	1	1	1

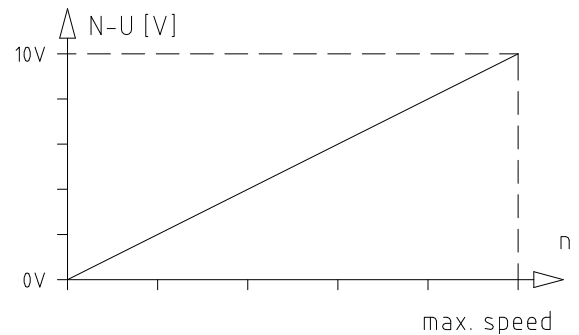

Illustration 20

Table 13: Selection of DATAFLEX® series

DATAFLEX® type	S5	S6
DATAFLEX® 22, 42, 85, 140	0	0
DATAFLEX® 16	1	1
DATAFLEX® 32	0	1

e) Digital input and output

The general parameters for calibration of the measuring shaft are stored electronically and can be changed by operating the external calibration input T1 and T2. As done in the connection box DF2 accessory the connections for the LED output and the calibration input are wired as shown in illustration 21 (see table 7).

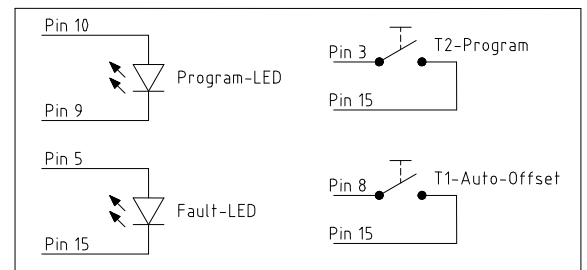

Illustration 21

LED 1 (Program)

For calibration of the measuring shaft the factors for amplification and offset can be set in steps. According to the description of the procedure in chapter 4 (calibration) the PROGRAM-LED shows a change in the mode of operation.

LED 2 (Error) / Error Signal

The perfect operation of the measuring system is permanently supervised.

An electronic defect is shown by an error signal. If an error is permanently shown, the measuring system is damaged and must be returned to KTR.



4 Assembly

4.10 Technical description

Table 14:

Condition	LED 2
Normal Operation	OFF
Error	ON

Automatic Offset Correction

If an incorrect value is indicated if no torque is applied ($\neq 5,0 \text{ V}$), an automatic offset alignment can be effected by pressing the button T1-Auto-Offset for 2 seconds.

For this purpose the torque is reduced to 0 and the button T1-AUTO-OFFSET must be pressed for 2 seconds. After successful alignment the saving of the new values is confirmed by 6-fold blinking of the program - LED and the normal measuring operation is continued automatically.

For an easy connection in control systems the Auto-Offset-Connection is accessible in the connection housing DF2 (No. 12).

5. Calibration (Manual adjustment of amplification and offset.)



ATTENTION!

The measurement shaft is delivered in calibrated state.

We recommended checking the calibration every half year.

The amplification determines the correct relationship between the torque and the output voltage as well as the output current. It influences the incline of the curves shown in illustration 14.1 and 14.2. The displacement of the curves in vertical direction depends on the offset alignment.

Both parameters can be set and saved one after the other (see illustration 22).

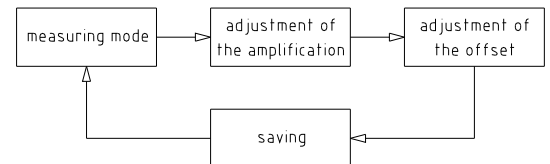

Illustration 22: flow of the manual setting

Instructions for a new calibration:

1. Press the T2-Program key for 2 seconds. The PROGRAM-LED will blink two times. An adjustment of the amplification factor is possible now.
2. The measurement shaft should now be alternately loaded and unloaded by a defined weight. The difference between the output values should be compared to the actual difference between the load and unload.
3. Through a quick press of the T1-AUTO-OFFSET key the amplification factor can be roughly varied. While a fine variation of the amplification factor can be made using a quick press of the T2-PROGRAM key. One after the other all of the types of amplification factors can be adjusted (see illustration 23.1).
4. If the difference of the displayed measurement values of the loading and unloading corresponds with the outside determined torque difference, the adjustment of the amplification is finished.
5. Press the T2-PROGRAM key for 2 seconds. The PROGRAM-LED will blink 4 times. The manual setting of the offset can start now.
6. As described under point 3 the keys can be pressed quickly to set all of the values (see illustration 23.2). If no torque is applied the measurement shaft should be adjusted to an output voltage of 5,0 V or rather an output current of 12,0 mA.
7. When the offset adjustment is finished, pressing the T2-PROGRAM key for two seconds will save all of the new parameters. The PROGRAM-LED will blink one time. The measuring shaft will be in its normal operating mode again.

Please note protection mark ISO 16016.	Drawn: 03.09.13 Pz/Koe	Replaced for: KTR-N valid from 28.05.13
	Verified: 22.10.13 Pz	Replaced by:



4 Assembly

4.10 Technical description

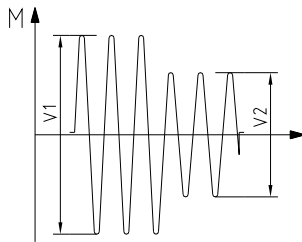

Illustration 23.1

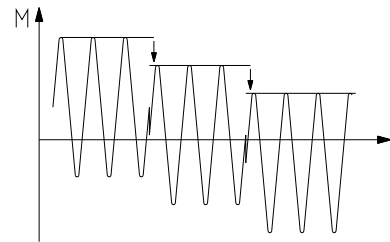

Illustration 23.2



CAUTION!

With saving all of the old data will be overwritten.



ATTENTION!

- The calibration can be interrupted if the measurement device is switched off for a short time and then switched on again. The previously saved parameters will then be reproduced.
- The safe measurement operation can be carried out after saving the new parameters (point 7) or after interrupting the power supply.
- After saving the new parameters (point 7) the parameters will stay the same even if the power supply is interrupted.

4.11 Services, customer service addresses

If requested we are pleased to perform the calibration of your torque measuring shaft and other services.

Contact addresses of the KTR partners for spare parts and orders can be obtained from the KTR homepage at www.ktr.com.



ATTENTION!

KTR does not assume any liability or warranty for the use of spare parts and accessories which are not provided by KTR and for the damages which may incur as a result.



5 EC certificate of conformity

EC Certificate of Conformity

The manufacturer - KTR Kupplungstechnik GmbH, D-48432 Rheine - states that the

torque measuring shaft DATAFLEX®

described in the present operating instructions is in accordance with the following standard:

2004/108/EG council directive of 15 December 2004 on the approximation of the laws of the Member States relating to electromagnetic compatibility and repealing directive 89/336/EEC.

Used standards:

DIN EN 61000-6-2: immunity for industrial environments
 DIN EN 61000-4-2: electrostatic discharge immunity test (ESD)
 DIN EN 61000-4-3: radiated, radio-frequency, electromagnetic field immunity test
 DIN EN 61000-4-4: electrical fast transient/burst immunity test
 DIN EN 61000-4-6: immunity to conducted disturbances, induced by radio-frequency fields
 DIN EN 61000-6-4: emission for industrial environments
 DIN EN 55011: radio disturbance characteristics (intensity of radio interference area class B)

Rheine,
City

28.05.2013
Date

i. V.
Reinhard Wibbeling
Engineering Manager

i. A.
Jürgen Kösters
Product Manager